



Manual for installation and maintenance

PYROS Explosion-proof Luminaire Models:

Pyros fluorescent

Pyros LED TUBES

PYROS LED / Pyros LED emergency autonomous block

PYROS WITH OPTIONAL WIRELESS CONTROL (iPyros)

PYROS WITH OPTIONAL DOUBLE CLOSING CAP



- 1) Explosion-proof Luminaire. General description
- 2) Safety instructions
- 3) Electrical connections
- 4) LED tube version
- 5) Fluorescent Emergency version
- 6) LED modules version and LED module emergency option. Autonomous emergency block version.
- 7) Installing the luminaire
- 8) Maintenance
- 9) Parts list
- 10) Guarantee conditions
- 11) Technical support
- 12) Technical Specifications

1) Explosion-proof luminaire. General description

- 1.1 Description of the Luminaire
- 1.2 General dimensions
- 1.3 Applications
- 1.4 Technical specifications
- 1.5 Transport and storage
- 1.6 Dismantling
 - 1.6.1 LED modules version components layout.

2) Safety instructions

3) Electrical connections

- 3.1 Connection cable
- 3.2 Stuffing glands and lid
- 3.3 Connection procedure
- 3.4 Circuit diagram

4) LED TUBE version

5) Fluorescent Emergency version

6) LED modules version and LED module emergency option. Autonomous emergency block version.

7) Installing the luminaire

8) Maintenance

- 8.1 Cleaning the luminaire.
- 8.2 Replacing fluorescent tube.
- 8.3 LED TUBES replacement.
- 8.4 Optional double-closing cap and through-wiring.

9) Parts list

10) Guarantee conditions

- 10.1 General conditions
- 10.2 Warranty Cover
- 10.3 Exceptions

11) Technical support

12) Technical Specifications



1) Explosion-proof Luminaire



1.1 Description of the Luminaire

The **Pyros** explosion-proof luminaire has been designed to operate in environments where explosive atmospheres may form or are present, in accordance with the ATEX 2014/34/EU Directive .

It consists of a tubular body of 4 mm polycarbonate, which provides high impact resistance, and is closed via aluminium caps at each end.

The **Pyros** explosion-proof lamp is designed for use with 18W, 36W and 58W T8 fluorescent tubes, along with the corresponding electronic ballast. The fluorescent tube can easily be changed via the connection cap. There are available versions with LED tube and integrated last generation LED modules.

The installation of the lamp is carried out using rubber-protected zinc-plated steel clamps.

The **Pyros** lamp has two cable inputs which are ready for the installation of stuffing glands or caps (NOT included) that have the explosion-proof certificates according with following cable glands marking:



II 2GD Ex db IIB+H2 T6 Gb
Ex tb IIIC T85°C Db

To avoid damage during handling and installation it is recommended that the steps described in this manual are followed and the conditions of use are adhered to.

The PYROS light fitting will be accompanied by the following documentation from AIRFAL INTERNATIONAL, S.L. on delivery:

- Explosion-proof luminaire.
- Installation and maintenance manual.
- UE examination Type Certificate.

1) Explosion-proof Luminaire



In the event of any part of this documentation being missing, contact the supplier or distributor of the equipment.

Explosion-proof luminaire

Model **Pyros** fluorescent 18W, 36W, 58W. LED tubes 400/600/1200/1500mm. LED Modules.

Protection Standard IP66

Fluorescent / LED tube: II 2 GD Ex db IIB+H2 T6 Gb / Ex tb IIIC T85 °C Db

LED module version, I-Pyros and Collator: II 2 GD Ex db IIB+H2 T6 Gb / Ex tb IIIC T85 °C Db

“

This luminaire is designed according to the following regulations :

EN IEC 60079-0:2018 “General rules”.

UNE-EN 60079-1:2014 “Explosion-proof casing” Ex db.

UNE-EN 60079-31:2014 “Casing protection” Ex tb

UNE-EN 60598-2-22 (Emergency versions only).

73/23/EC. Low Voltage Directive

89/336/CEE. EMC Directive

93/68/CEE. EC Mark Directive

2014/34/EU. Directive regarding equipment and protection

Systems for use in explosive atmospheres



1.2 General Dimensions

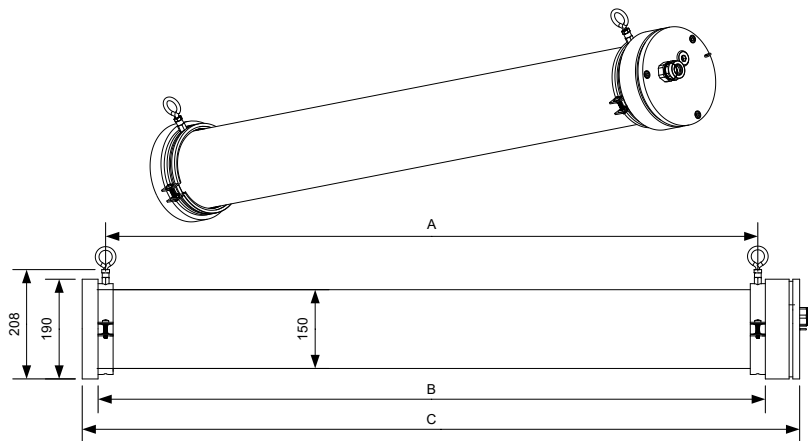

POWER (Fluorescent / led tube)	POWER (LED modules version)	A	B	C
—	7/14	318	346	440
18W	14/28	626	654	748
36W	28/55	1235	1263	1357
58W	35/70	1537	1565	1659

1) Explosion-proof Luminaire



1.2.1 Double closing cap version Dimensions.

POWER (Fluorescent / led tube)	POWER (LED modules version)	A	B	C
---	7/14	315	344	474
18W	14/28	625	618	784
36W	28/55	987	1059	1393
58W	35/70	1195	1287	1695

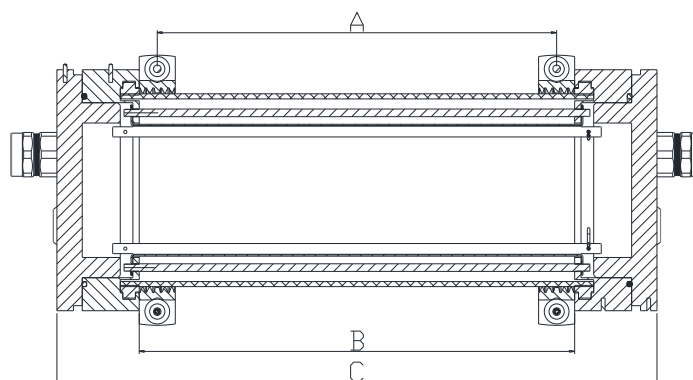

1) Explosion-proof Luminaire



1.3 Applications



The **Pyros** explosion-proof light fitting has been designed to operate in environments where explosive atmospheres may form or are present, in accordance with the ATEX 2014/34/EU Directive. This excludes its use for other applications.

It is recommended that this light fitting be used in an ambient temperature of $-20^{\circ}\text{C} < T < 55^{\circ}\text{C}$ for fluorescent version, and $-20^{\circ}\text{C} < T < 50^{\circ}\text{C}$ for LED tube version, LED modules version or fluorescent with optional emergency kit.

The observation of these instructions is considered part of the lamp's designated use.

1.4 Technical specifications

The certification for the **Pyros** explosion-proof light fitting is:

Fluorescent / led tube:  II 2 GD Ex db IIB+H2 T6 Gb / Ex tb IIIC T85 °C Db
LED module version, I-Pyros and Collator:  II 2 GD Ex db IIB+H2 T6 Gb / Ex tb IIIC T85 °C Db

The luminaire complies with the corresponding regulations with reference to materials for explosive environments and protection via explosion-proof casing.

Section 9 gives details of the most significant technical specifications of the luminaire.

1.5 Transport and storage

1.5.1 Transport

- The luminaires must be transported in sufficient packaging. Take appropriate measures and make provisions to avoid knocks.
- Any webbing, sling, rope or chain used during the transport of the luminaire must NOT under any circumstances be attached to the lamp itself.
- Knocks against walls, floors, and any other equipment during transport of the luminaire may cause serious damage to the luminaire or its components.

1.5.2 Storage

- The luminaires should be stored in dry, well ventilated areas in the original packaging.
- Avoid putting the luminaires directly on the floor. Make appropriate storage arrangements .

1) Explosion-proof Luminaire

- Cover the luminaires to protect them from dust and dirt
- Keep the sealing caps closed that keep the equipment airtight. If these have been interfered with, check that the sealing remains airtight.
- Keep the technical documentation which accompanies each luminaire in a safe place.

1.6 Dismantling (fluorescent / LED tube versions).

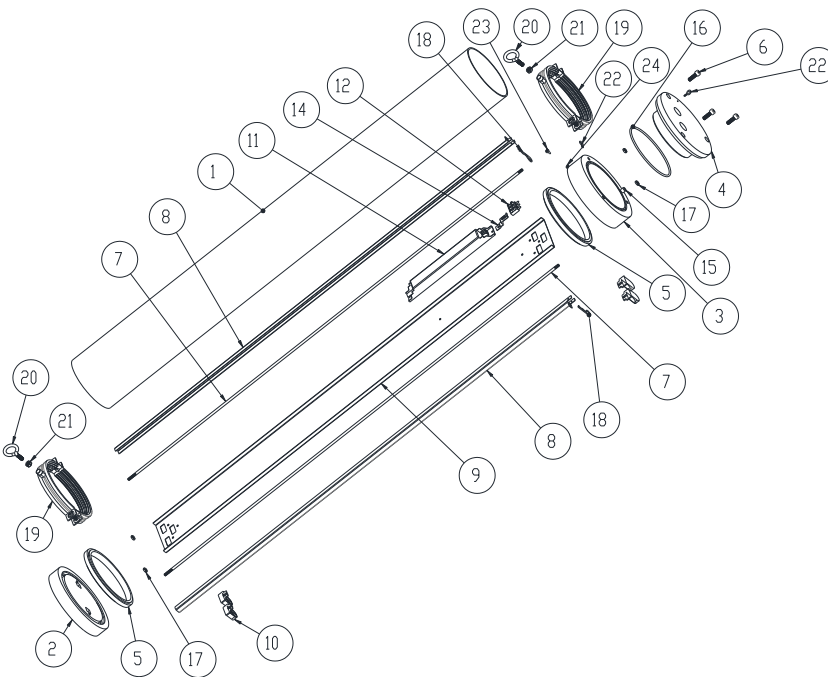

Item	Unit	Description	Item	Unit	Description
1	1	Polycarbonate tube	14	1	Support tab
2	1	Lower cap	15	1	Guide pin
3	1	Upper cap	16	1	O-ring seal
4	1	Closing cap	17	4	M6 Nut
5	-	Polyurethane resin	19	2	Clamp
6	3	M8 Allen screws	20	2	Fixing eye bolts
7	2	Fixing bar	21	2	M8 eye bolt nut
8	2	Reflector guide	22	2	Chain eye bolt
9	1	Reflector	23	1	External Earth screw
10	4	Lamp holder (fluor. / LED tube versions).	24	1	Earth washer
11	1	Ballast / LED driver			
12	1	Terminal block			

1) Explosion-proof Luminaire



1.6.1 Dismantling (LED VERSIONS).

In LED module versions, the enclosure is exactly the same, but the internal parts layout on the gear tray is different. The LED modules layout is this:

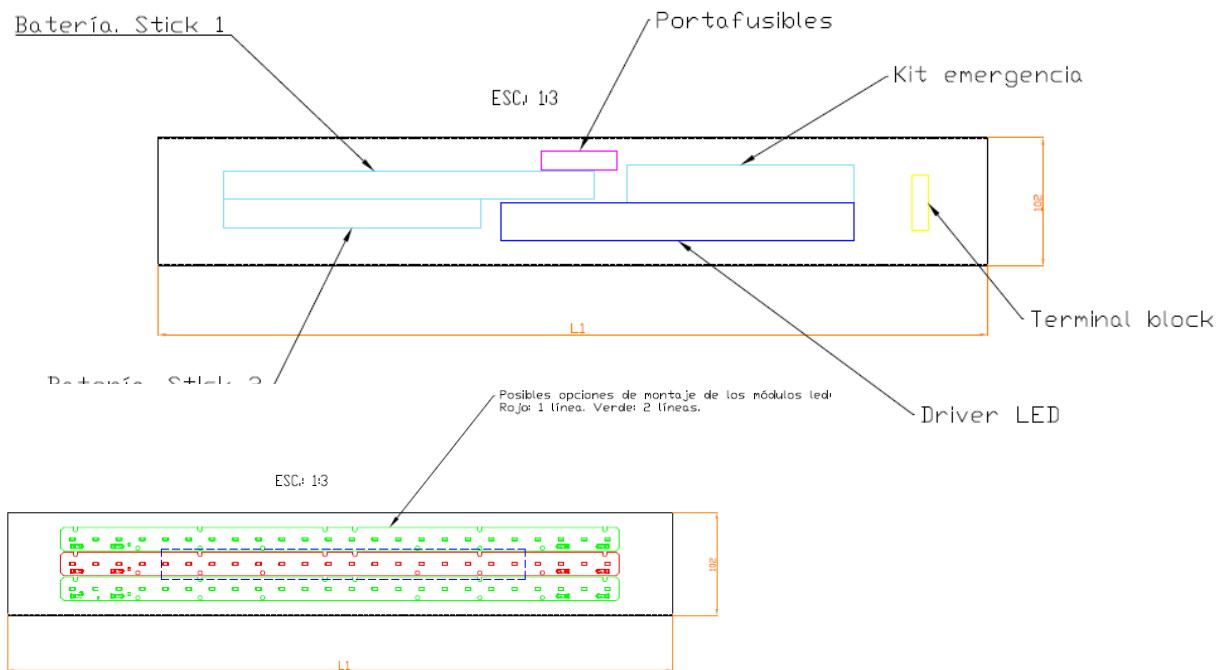

In case of double cap versions, this is the enclosure structure:

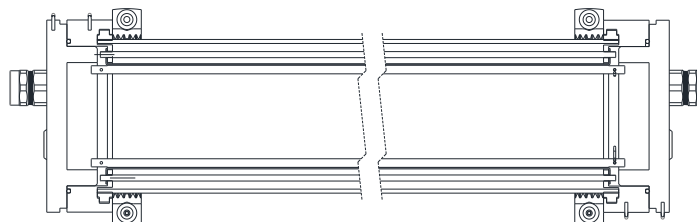

Gear tray is introduced in the same way that standard versions.

1) Explosion-proof Luminaire



Collator Layout and components:

Those are the main components in collator version:

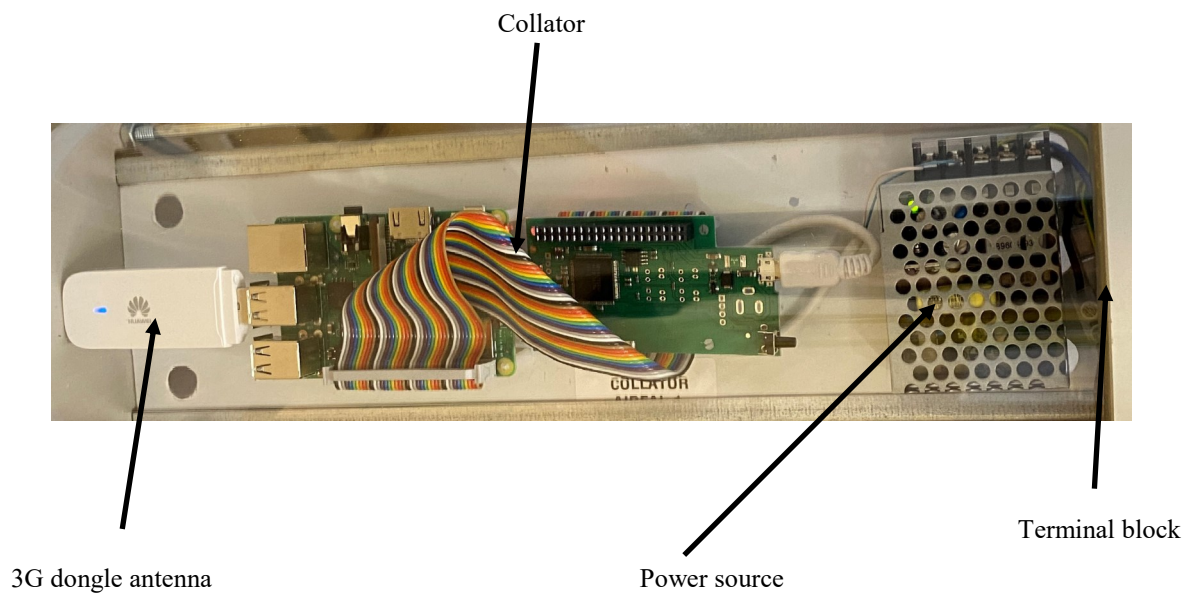

2) Safety Instructions



The applicable Directives and regulations concerning the use of devices, and any work carried out in dangerous areas (Environments with a risk of explosion due to an explosive atmosphere) must be observed during the time the light fitting is being installed.

The classification of dangerous sites into areas is the responsibility of the user whose installations or activities contain or are the origin of the such dangers.



Do not open the light fitting when it is switched on. **Wait 30 minutes before opening the lamp in normal working conditions** ($-20^{\circ}\text{C} < T < 55^{\circ}\text{C}$ for fluorescent version, and $-20^{\circ}\text{C} < T < 50^{\circ}\text{C}$ for LED tube version, LED modules version or fluorescent with optional emergency kit) so that there is no residual electrical charge in the equipment.

Do not open when an explosive atmosphere is present.

Any transformation or interference with the lamp or its components - which is different to that indicated in the maintenance section - is prohibited, unless previously authorized in writing. Improper handling could lead to a reduction or loss in the protection against the risk of explosion afforded by the equipment.

Work on the electrical systems or equipment must only be carried out by a qualified technician or specially instructed personnel under the control and supervision of those technicians, in accordance with the applicable safety regulations. Any qualified personnel must be familiar with all the cautions and warnings described in these instructions. Non-observance of these cautions and warnings could lead to serious personal injury and material damage, for which AIRFAL INTERNATIONAL S.L. will NOT be held responsible.

Flameproof joints are not intended to be repaired.

The light fitting can only be installed in locations with a low risk of impact.

WARNING: POTENTIAL ELECTROSTATIC HAZARD. SEE CLAUSE 8.1. It is very recommended to use ESD protection clothes and gloves to avoid LED damages because of electrostatic discharges.



3) Electrical connections



Before making electrical connections the safety instructions from the previous section must be observed.



Each PYROS luminaire is accompanied by technical documentation from AIRFAL INTERNATIONAL S.L. on delivery.

Section 9 gives the electrical specifications of the luminaire.

There is an external earth connection identified with a sticker, via an M4 screw and a toothed washer on the upper cap, next to the cable entry point.

3.1 Connection cable (NOT included)

The explosion-proof luminaire power supply cable will be three-pole, with a maximum section of 2.5 mm².

A suitable cable must be used to connect perfectly both with the luminaire and using the stuffing glands that are to be installed.



The use of an unsuitable cable could render luminaire operation UNSAFE under normal conditions, in addition to causing a loss of the guarantee in the case of any malfunction or fault.

AIRFAL INTERNATIONAL S.L. will NOT be held responsible for any malfunction of the luminaire due to the use of an UNSUITABLE cable.

3.2 Stuffing glands and cap (NOT included)

The **Pyros** luminaire has two cable inputs with an M25 (ISO 965/1) thread on the closing cap.

In cases of installation in a continuous line two stuffing glands must be used, one for the entry cable and one for the exit cable. The glands must be threaded more than 5 threads.

Otherwise it is necessary to use one stuffing gland for the entry cable and a explosion-proof cap to close up the other hole.



Both the stuffing glands and caps must be marked up as follows, in accordance with the 2014/34/EU (ATEX) Directive:

Fluorescent / LED tube:

II 2 GD Ex db IIB+H2 T6 Gb / Ex tb IIIC T85 °C Db

LED modules version, I-Pyros and collator:

II 2 GD Ex db IIB+H2 T6 Gb / Ex tb IIIC T85 °C Db

The use of unsuitable stuffing glands and/or caps could render light fitting operation UNSAFE under normal conditions, in addition to causing a loss of the guarantee in the case of any malfunction or fault.

AIRFAL INTERNATIONAL S.L. will NOT be held responsible for any light fitting malfunction due to UNSUITABLE stuffing glands and/or caps being used.

3) Electrical connections



3.3 Connection procedure

It is recommended that the steps for connecting the light fitting are carefully followed to ensure correct operation.

It is recommended that a check is carried out to ensure there is NO electrical charge in the cable before starting the connection work.

The lamp has a rapid connection system in its interior via a plug-in terminal strip connection. The current cable is connected to the strip female terminal. This allows the lamp to be disconnected in order to work safely without any remaining electrical charge when the fluorescent tube is being replaced.

1. Use a 6 mm Allen key to remove the three screws that hold the closing cap, as seen in the figure. Then remove the closing cap, keeping it perpendicular with respect to the fitting axis in order to facilitate its removal.
2. Insert the stuffing gland(s) and/or caps in the corresponding holes. Make sure they are correctly fixed to the closing cap (At least 5 threads). Thread the cable(s) through the stuffing gland(s).
3. Remove the stop pins from the reflector guide and remove the reflector from the fitting.
4. Insert the fluorescent tubes in the fitting holders and replace the reflector in the same position in the fitting (ensure that the guide pin is on the same side as the fluorescent tubes).
5. Replace the two stop pins in the reflector guides.
6. DO NOT TOUCH WITH FINGERS the LED modules in the luminaires with this option.

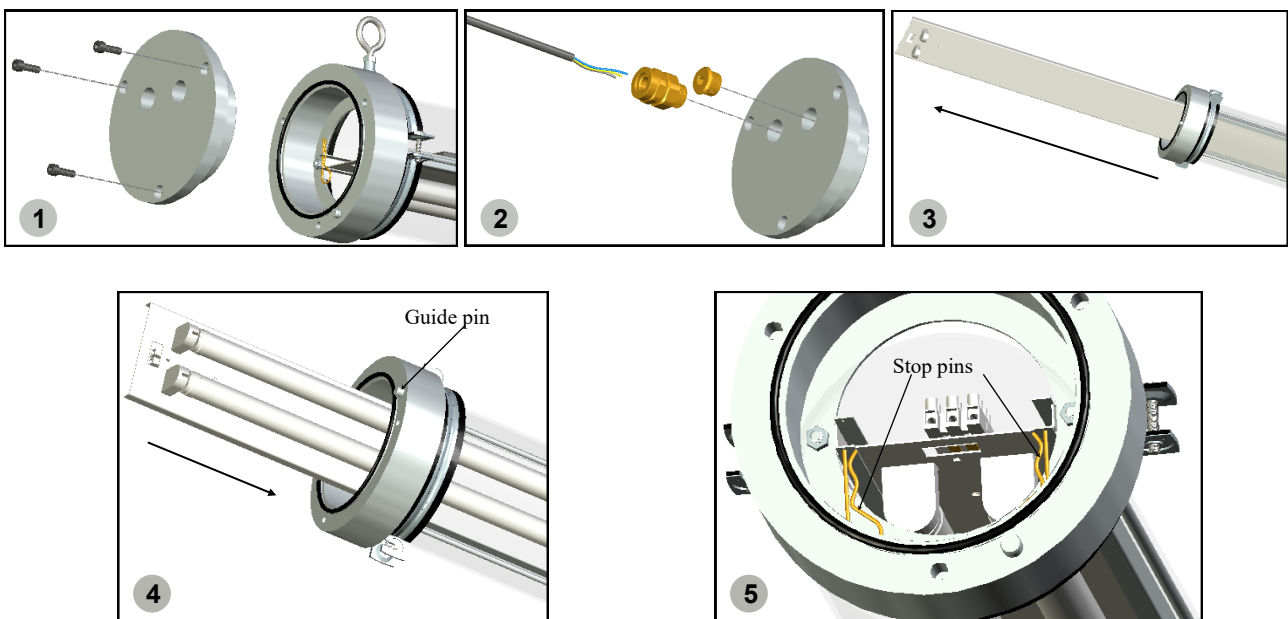

3) Electrical connections



6. Connect the supply cables to the terminal block. Once the plug has been connected replace it in its original position. Earth wire must be connected to this terminal block, in the signaled terminal. This earth connection ensure ground continuity between gear tray and metallic parts of enclosure.
7. Terminal block can allow wires up to 6mm^2 cross section. Minimum cross section of earth conductors shall be at least equal to cross section of phase conductors.
8. Ensure that the supply cables are correctly attached through the cable glands using a 35 spanner (or a wrench).
9. Close the fitting, making sure that the guide pin on the upper cap fits into the hole of the closing cap.

10. Use a 6 mm Allen key to tighten the three screws which hold the closing cap. The screws are **M8 Allen DIN 912 stainless steel property class A2-70**. If this screws are replaced, the new ones **MUST** be exact model and class.

11. If installer choose armored cable, an armored cable compatible cable gland must be installed. Connectioni armour to the cable gland, external eathing connection is granted. If installer uses a non-armored cable, you can connect a earth cable to the screw that fix the closing cap chain, using a tag attahed to the earth cable. Minimum cross section of earth conductor is 4mm^2 .

12. Turn on the power, and make sure the lamp tubes or LED boards are working correctly.

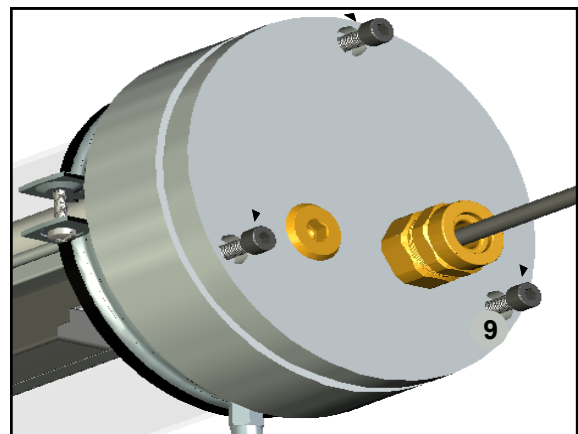
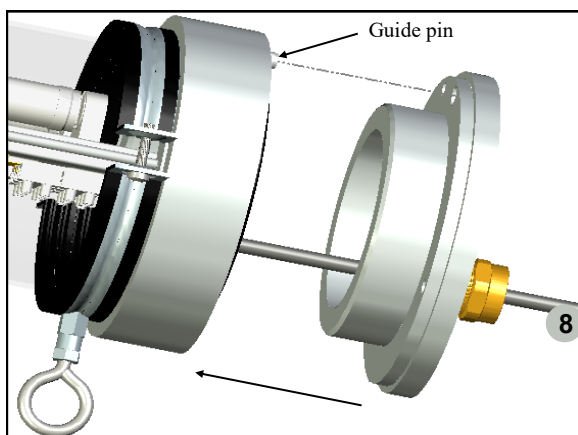
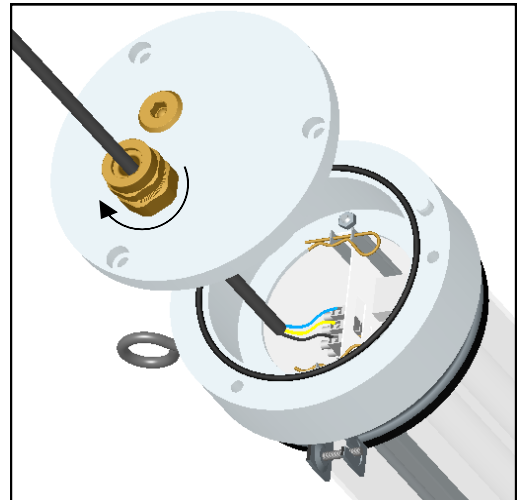

Check that all components are correctly fitted in their respective positions and that all fastenings have been fully tightened.

AIRFAL INTERNATIONAL S.L. will not be held responsible for any problem resulting from incorrect or incomplete assembly and connection.

3) Electrical connections



3.4 Circuit diagram

One-tube Luminaire

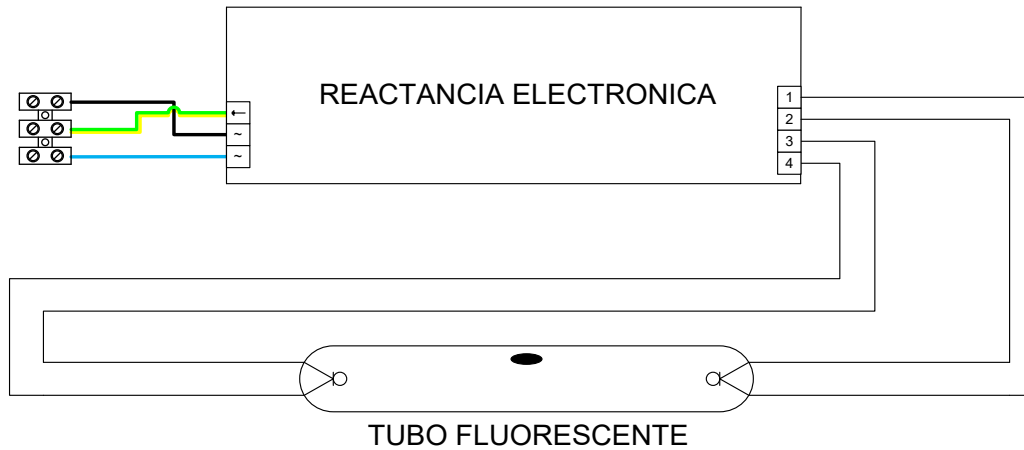

Two-tubes Luminaire

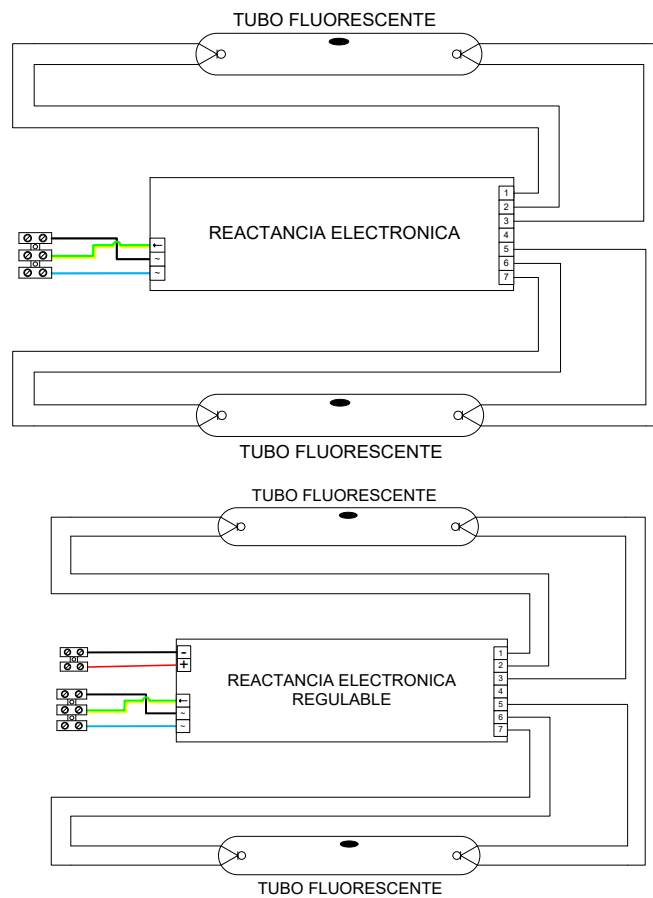

4) LED TUBE Version



Possible LED Tube connections:

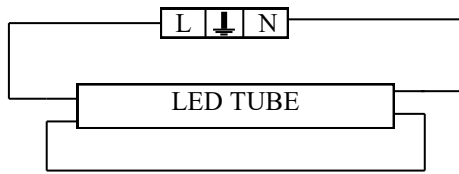

TYPE 1

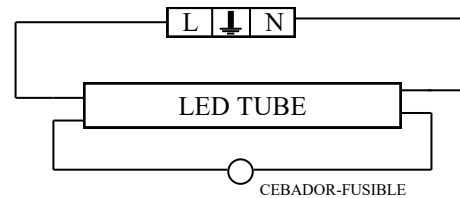

TYPE 2

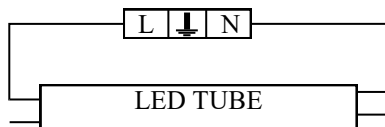

TYPE 3

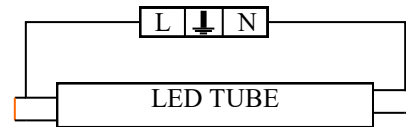

TYPE 4

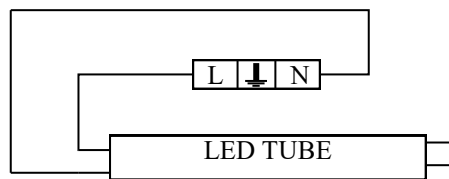

TYPE 5

In case of double closing cap version, the added wiring is:

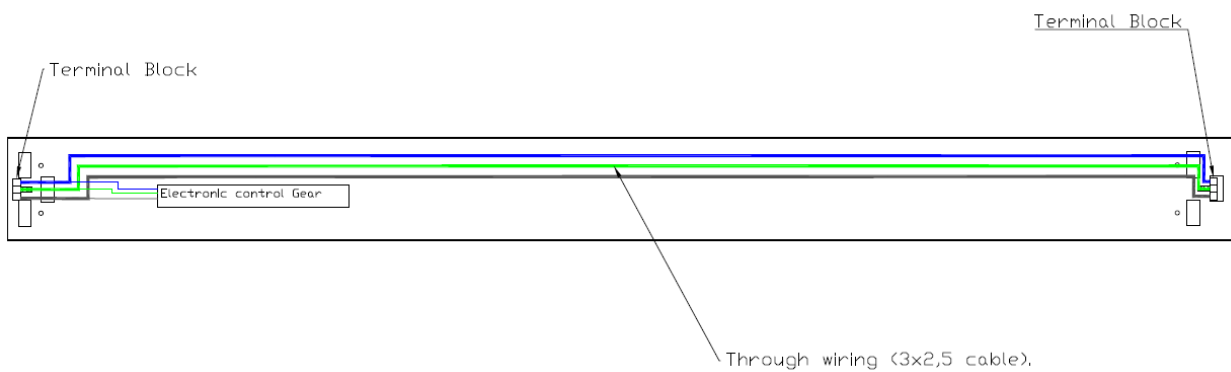

5) Fluorescent Emergency Version



Stand to the essential requirements of the directives :

- Low Voltage Directive: 2006/95/EEC.
- EMC Directive: 2004/108/EEC.
- 2014/34/UE Directive.

And agrees the following harmonized documents:

- UNE-EN6347-2-7: Lamp control gear -- Part 2-7: Particular requirements for d.c. supplied electronic ballasts for emergency lighting.
- UNE-EN 60598-1: Luminaries-specification for general requirements and test.
- UNE-EN 60598-2-22: Luminaries for emergency lighting.
- UNE-EN 55015-1: Limits and methods of measurement of radio disturbance characteristics of electrical lighting and similar equipment
- EN 61547: Equipment for general lighting purposes. EMC immunity requirements.
- UNE EN 61000-3-2: Limits for harmonic emissions.
- EN IEC 60079-0 : 2018: Explosive atmospheres - Part 0: Equipment - General requirements.
- EN 60079-31: 2014: Explosive atmospheres. Equipment dust ignition protection by enclosure "t".
- EN 60079-1: 2014. Explosive atmospheres - Part 1: Equipment protection by flameproof enclosures "d".

Technical characteristics:

Voltage: 220-240V / 50-60Hz - **Consumption:** 3W - **Line current:** 15mA - **Power factor (cosΦ):** 0,87

Efficiency:

 T8 (G12)		
18W	36W	58W
27%	22%	20%

5) Fluorescent Emergency Version



- **Battery charging time:** 24 Hours.
- **Autonomy nominal:** 180 minutes.
- **Battery:** 3,6V (3 Ni-Cd 1.2V cells) Capacity: 4Ah.

Useful life estimated at 4 years with a frequency of one month discharge.
24 hours charge period. Charge current: 200mA.

- **Indication**
Charging process indicator LED.
- **Protections**
Protected against the entrance of liquids and solids: IP20.
- **Envelop:** grey polycarbonate (RAL 7035)

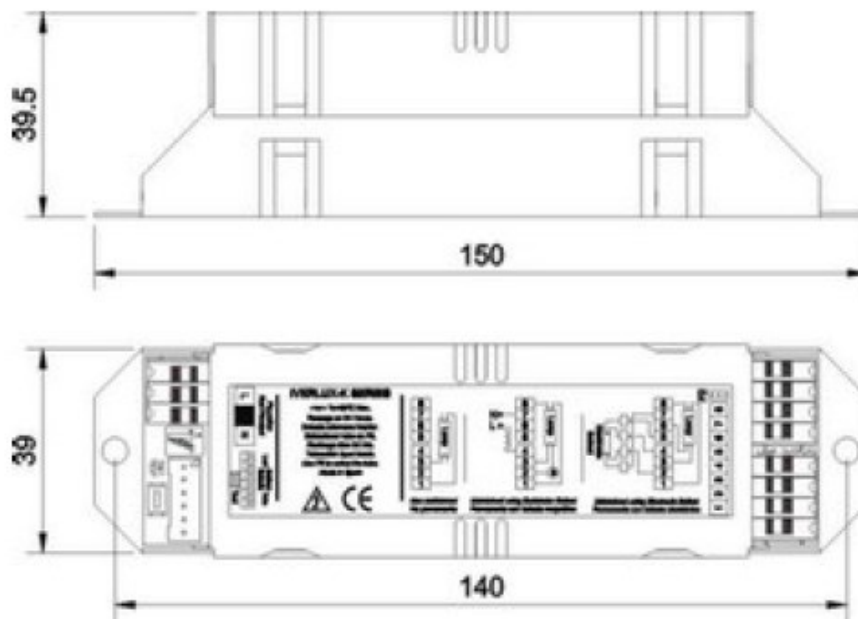

6) LED module version with optional emergency and emergency block version.



There are available a LED module light source versión. This version mounts last generation integrated in the internal structure, controlled by constant current electronic driver.

Available versions:

PYROS LED MODULES		
POWER (W)	LIGHT EMISSION (lm)	LED ROWs
14	2150	1
28	4300	2
28	4300	1
55	8600	2
35	5370	1
70	10740	2

This version is designed to be used in big heights in industrial zones, because of their high light emission, low power and very low maintenance.

There is available a 3 hours emergency version.

- **Battery charging time:** 24 Hrs.
- **Battery life:** up to 180 minutes.
- **Battery:** 6V (5 NiMH 1.2V cells) Capacidad: 4Ah.

Collator version: 230V, 10W máximum power. Enclosure: 440mm length.

Estimated battery life: 4 years with a monthly discharging frequency.

Charging time: 24 hours. **IMPORTANT NOTICE:** It's VERY HIGHLY recommended to make at least two complete charge/discharge cycles before ending installation/commissioning to ensure good performance of batteries.

- **Charging indicator:**
LED.
- **Protection against liquid and solid penetration, IP66**

Emergency autonomous block versión:

PYROS LED EMERGENCY AUTONOMOUS BLOCK	
SIZE (mm)	LIGHT EMISSION (STANDARD / EMERGENCY MODE)
440	500
440	800
748	800
748	4300 / 950
1357	4300 / 950
1659	10740 / 950

7) Installing the Luminaire



The installation must be carried out by qualified professionals and according to the manufacturer's instructions. Incorrect installation could cause damage to persons, animals and assets for which the manufacturer would not be considered responsible.

The installation of the luminaire will be carried out once the electrical supply has been installed and checked, and the luminaire has been completely sealed in accordance with the connection procedure.

The PYROS luminaires shall be installed according EN60079-14 and EN60079-17 standards.

The installation is carried out using the two zinc-plated steel clamps with rubber protection, and the hooks screwed to them. Make sure that the luminaire is not in contact with – nor that it scrapes against – any other elements during fitting. See drawing below:

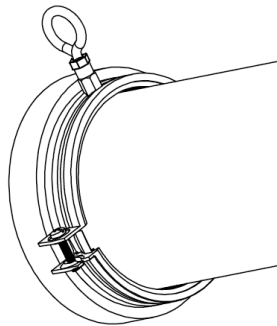

The luminaire must be maintained at a safe distance from other elements in the area.

The explosion-proof luminaire must be installed in places away from sources of heat or cold that could significantly vary the luminaire working temperature.

LED modules versión must be installed in the same way that the fluorescent way, but beignd very careful of not touch LED modules with fingers. It is very recommended to use ESD protection clothes and gloves to avoid LED damages because of electrostatic discharges.



IMPORTANT NOTICE: REPLACEMENT OF THE BATTERY PACK, please contact the manufacturer.

7) Installing the Luminaire



7.1.- OPTIONAL WIRELESS CONTROL. TABLET SOFTWARE SETUP.

There are some settings within the tablet that will make improve your user experience which are laid out below.

NOTE: Tablet for configuring and commissioning is not included under ATEX certification INERIS 14ATEX0064X. It can't be used in an ATEX classified area.

Screen Timeout

The default setting for the screen to go into sleep mode is 30 seconds. Navigate to the settings option on the tablet then Display & adjust the Screen Timeout 5 minutes as a minimum.

TeamViewer Quick Support

TeamViewer is a programme that will allow LitelP to remotely access your tablet when you allow them to and give assistance during commissioning. To download it go to the google play store and search for "TeamViewer Quick Support" You want to download TeamViewer QuickSupport (pictured first in the left image) and Add-On: Samsung. Once installed you simply need to open the app and provide the 9-digit code to the LitelP staff member helping you. This app does require

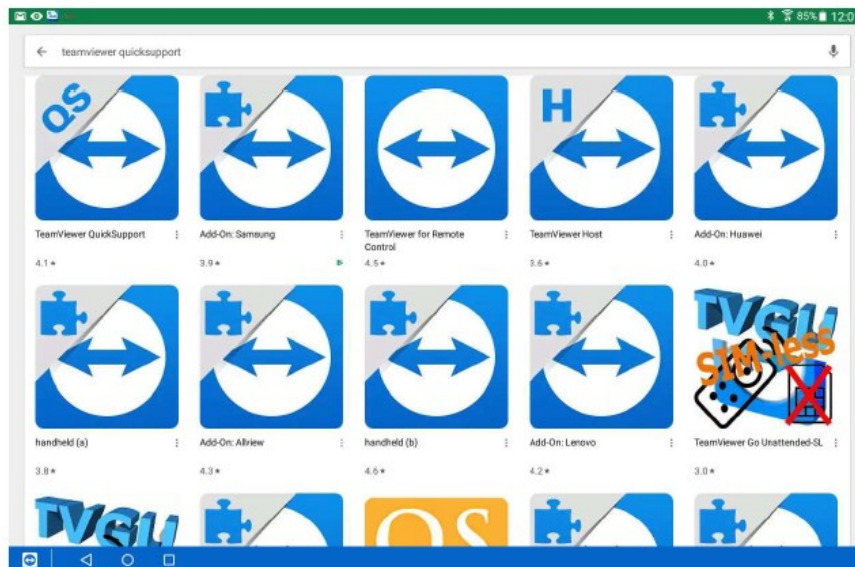

7) Installing the Luminaire



Software References.

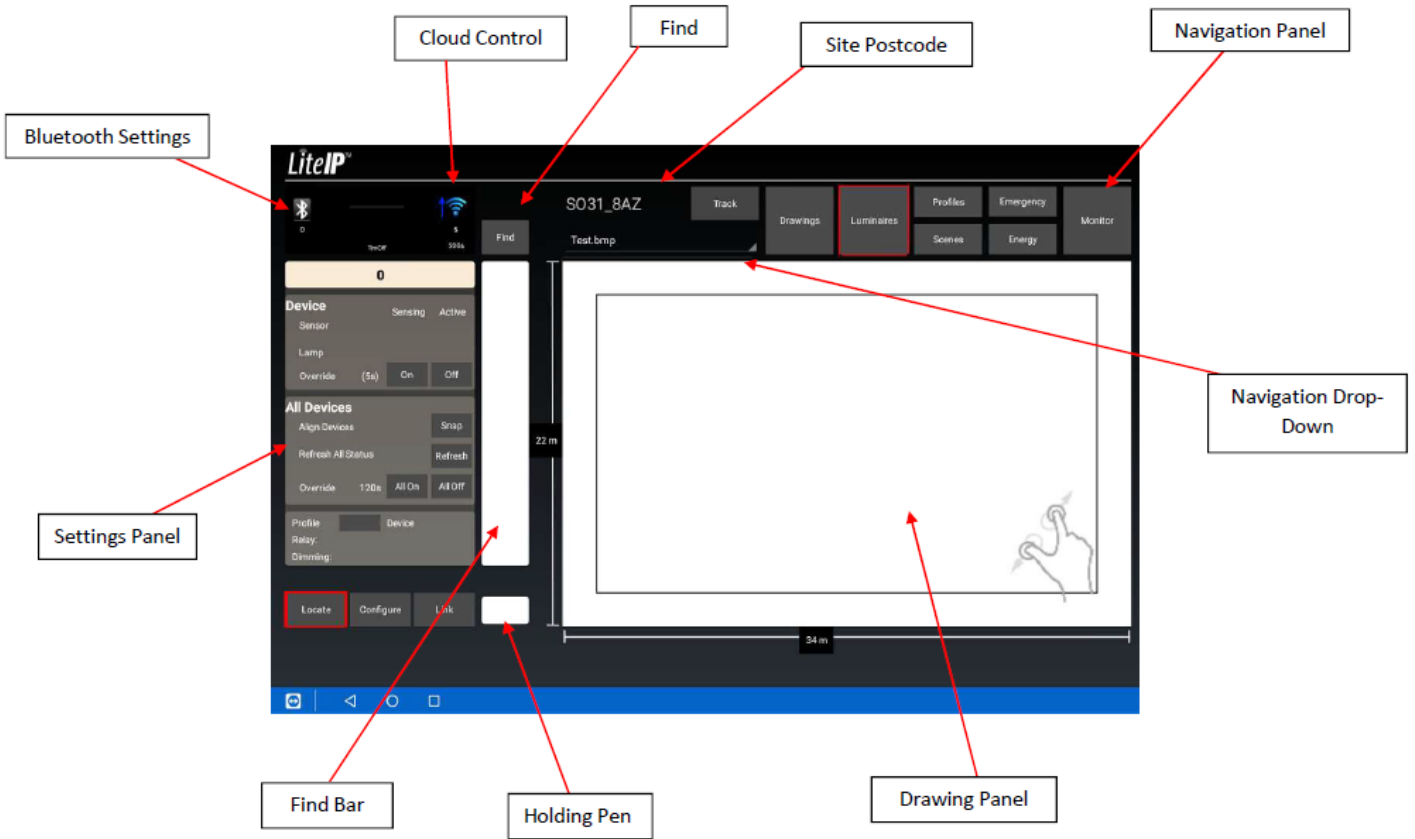

7) Installing the Luminaire



Connecting your LiteIP Mate

To connect a Bluetooth LiteIP mate first make sure it is turned on (you will see a green light on) and tap on the Bluetooth Settings button, this will bring up the menu seen in the picture left. Then tap discover in the bottom left of the new drop-down menu and this will begin to search for any LiteIP mates locally.

Once it has found a LiteIP mate it will tell you the ID and begin to connect, follow the process through and press accept when asked if you would like to pair it with the tablet. You Will know when the connection is complete as the Bluetooth setting button will turn into a blue circle (pictured in second image) After you have set up a LiteIP mate it should automatically connect if turned on and close to the tablet in the future.

The LiteIP Mate can be turned off manually via the small pinhole next to the micro-usb charging point. Use a small object to press the button inside, a red light will blink and tap again. Alternatively, the device will put itself into sleep mode if disconnected from the Tablet and inactive for 5 minutes. To wake it up simply turn it over. Recommendations for charging are that the device is turned ON and charged from a computer or laptop. A red blinking light below the green light will indicate you are running low on charge.

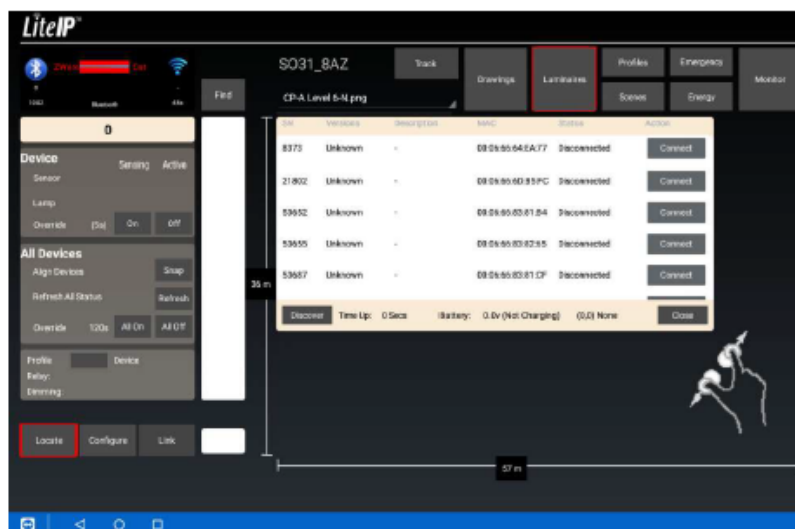
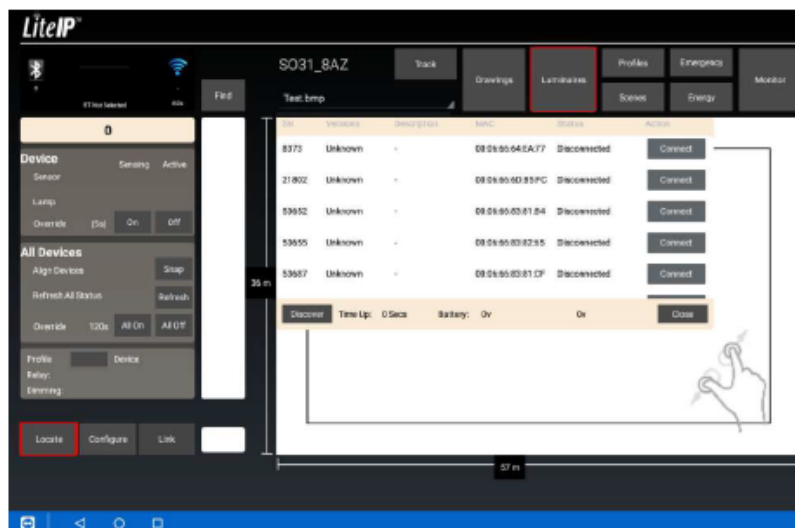

7) Installing the Luminaire



Creating a New Site

This is the Home Page for the LiteIP Control App. You can return here at any point by tapping on the site postcode. On this page you can view the sites you have set up locally on the tablet or have available to download from the server. If you tap on a postcode under "Postcodes on Tablet" you will be able to see information related to that site. This will not work if you select a drawing under "Postcodes on Server" as the data must be downloaded first (see Downloading Postcodes section) To create a new site you want to tap on the "Add New Postcode" button which is located just under the Active Database.

This will open the postcode window. Simply enter both parts of the postcode and tap Validate, Register and then download. After 30 seconds you can then press close. This Will have now created the postcode within your "Postcodes on Tablet" window. Tap on the newly created postcode and then the drawings tab in the navigation panel.

If the postcode has already been created then after pressing Validate you will be prompted to press Download and not Validate.

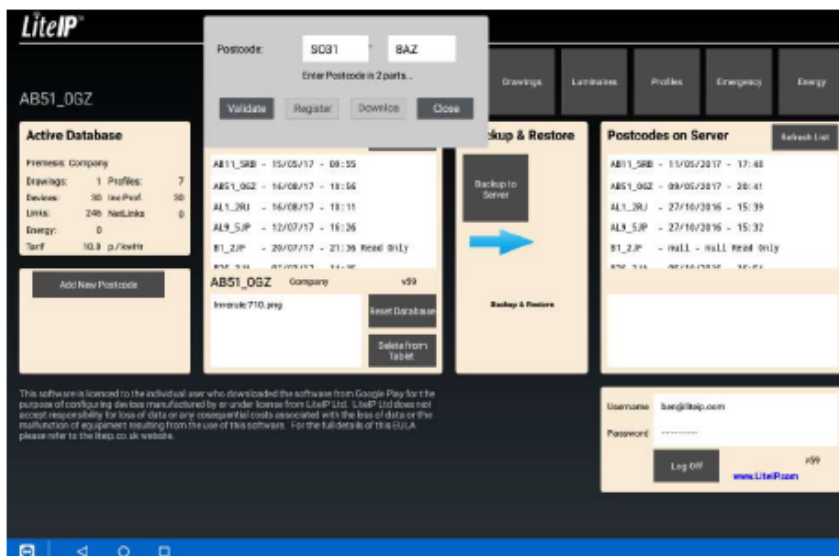
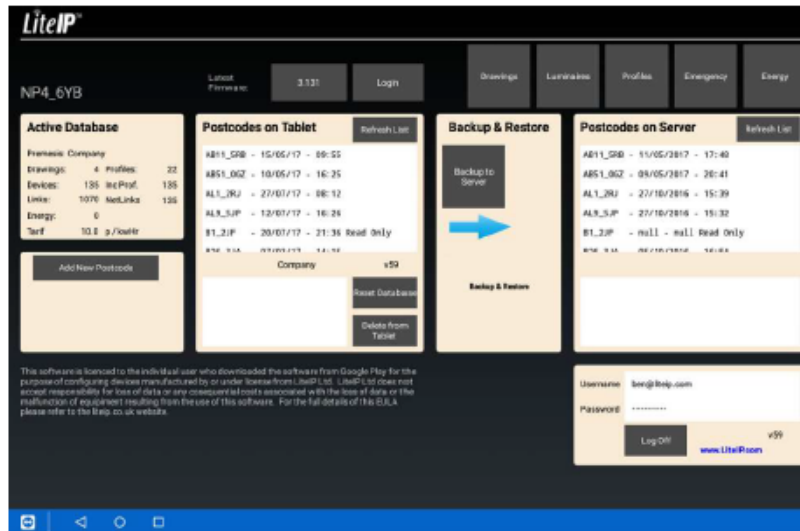

7) Installing the Luminaire



The drawing tab will open the screen opposite. You have two options when creating a new drawing, either create a blank drawing or import a JPG of a CAD drawing to work on. To create a blank drawing you need to tap the “New” button and then “Create” This Will prompt you to enter a drawing name and the X dimension for the width of the area you are creating.

Once created you can click the Modify button which gives you options such as adding a door or window so you can easily understand the orientation of the area once you start to add luminaires. You can also add a grid over the area as to replicate a 600x600 or 1mx1m ceiling grid.

If you add any of these modifications you must click save before being able to proceed.

To import a drawing you must first import it on to the tablet within the Device Storage > Download folder. The image must be PNG / JPG / GIF file type. Once it is loaded on to the tablet navigate to the “New” tab and then “Browse” this will then give you a list of all the available image files you have, simply select the one you require and click “Okay” You Will then be prompted to enter an X axis dimension.

After you’ve created your drawing, either blank or with an imported image then click the “Luminaires” tab in the Navigation Panel.

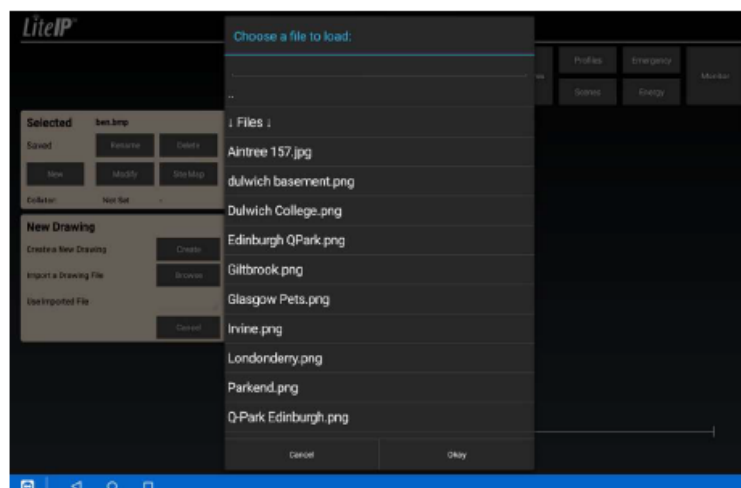
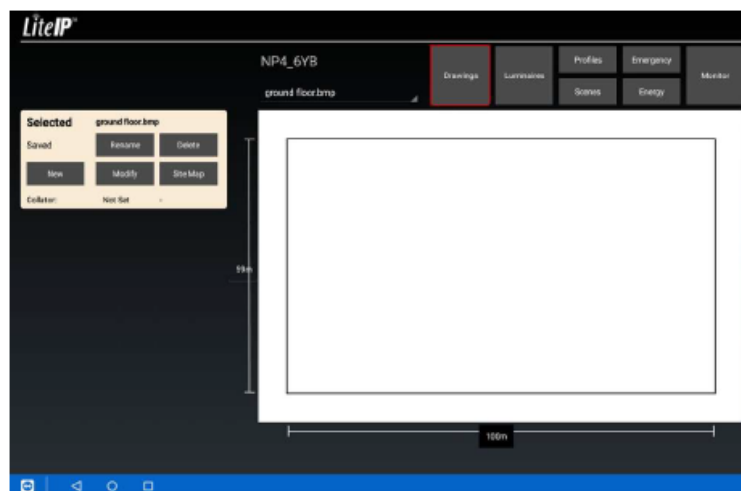

7) Installing the Luminaire



Pre-Commissioning

You can create simulated devices within the commissioning software that allow you set up your parameters before visiting site, making on-site commissioning much quicker. To do this you drag a square over the area you wish to add the devices starting top left and ending bottom right and you should get a yellow square (shown opposite) This will then give you an option in the settings tab to “Simulate Array” If you press this you can then enter create an array of devices X by Y.

You will then get a layout as per the image left. The devices you’ve created here are not real LiteIP nodes but placeholders. You can apply your settings / control groups to them and then replace the ID whilst on site where the real device will take on all the settings you’ve applied.

If you re-select the group of luminaires you will get a movement tool in the bottom right of the Drawing Panel, this will allow you to move the entire array. Tapping near the end of the tool will shift the luminaires more than tapping near the centre.

An orange coloured luminaire will always indicate a simulated device.

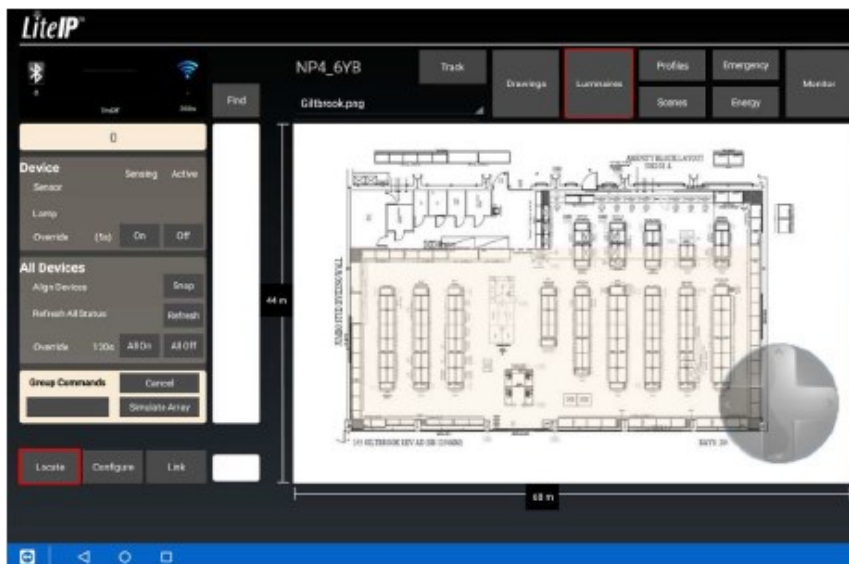

7) Installing the Luminaire



Creating Profiles

The next step is to set up profiles for the luminaires which hold all the parameters we want applied to the device. To access this menu you need to select the "Profiles" tab in the Navigation Panel and then select the "Components" option by tapping to the left of it, this will give you to the page you see opposite. You have a drop-down menu underneath the site postcode. This menu will show all your current profiles.

You can create as many as you want and rename them at any time. These instructions Will be based on editing the default profile but it is recommended that you create your own profiles and leave the default.

If you select the Driver box this will give you options to the left. These are the following:

- x OnLevel – The maximum output the luminaire will go to
- x StandbyLevel – The output the luminaire will dim down to
- x FadeTime – The time taken for the luminaire to dim from its OnLevel to its StandbyLevel
- x StandbyTime – The time until the luminaire will turn OFF after dimming down to its StandbyLevel
- x PowerON – The wattage of the luminaire at full output, this is used for energy data

If you want the luminaires to never turn off and simply remain in at their StandbyLevel then enter 127.5 minutes in the StandbyTime option.

There is also a drop-down menu that allows you to select the type of driver being used within the luminaire.

For the settings we have here the luminaire will come on at 100%, dim down to 10% once the PIR has timed out over a period of 30 seconds and then turn off after a further 30 minutes.

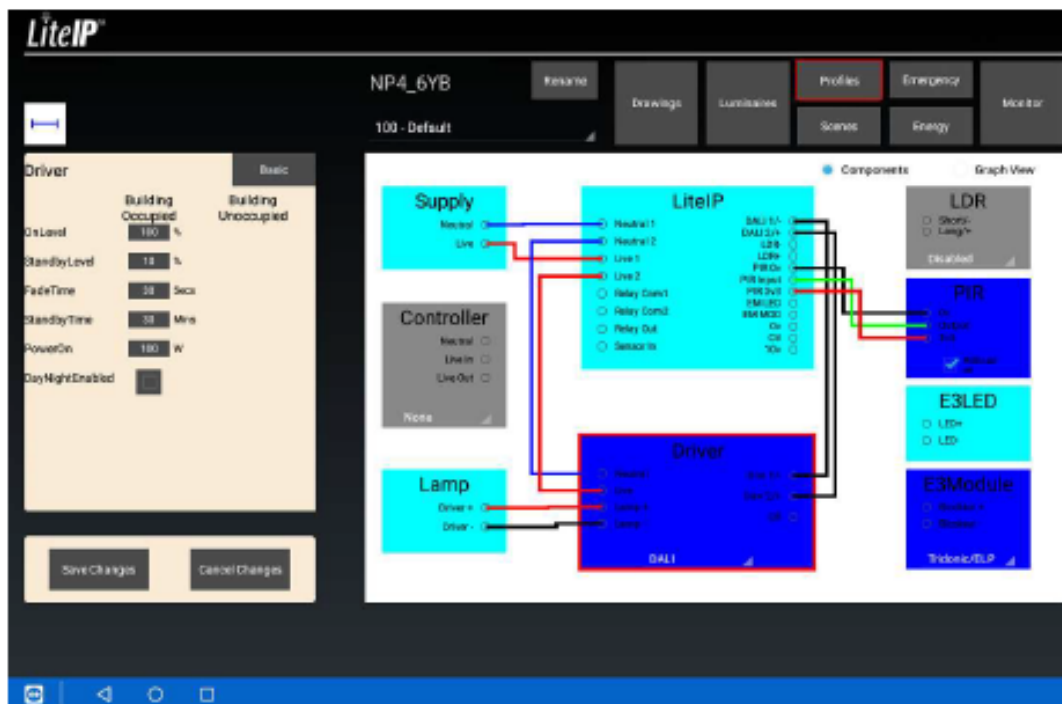
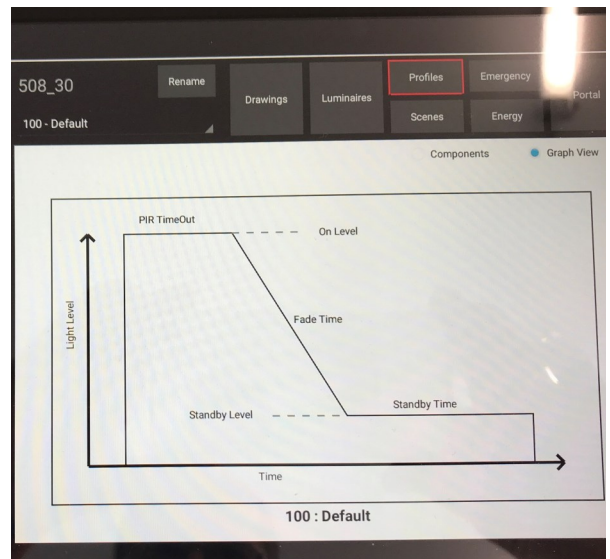

7) Installing the Luminaire



Within the profiles setup you are also able to adjust the PIR timeout if you are using one. If you are using a LiteIP 3v PIR then tick the PIR box (as outlined in red opposite) This will give you the PIRTimeOut option within the Settings Panel.

Here you can adjust the PIR Timeout from 30 seconds upwards. This setting is the period after the PIR last detected presence that the luminaires will begin to dim down to their StandbyLevel.

If you are using a mains sensor then repeat the above but select 230v PIR from the dropdown menu in the Controller box (highlighted red opposite).

Once you've completed setting up your profiles select Save Changes in the bottom left and say Yes when prompted. If you make changes to a profile that you have already assigned to luminaires then you will be asked if you also wish to make the changes to those devices, to which you should also say Yes. Once you've done this return to the Luminaire page.

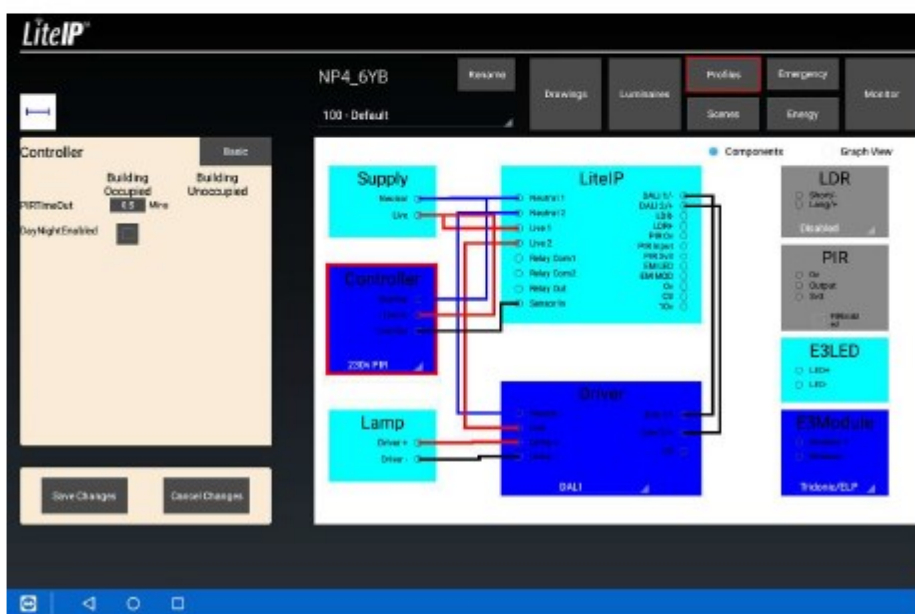
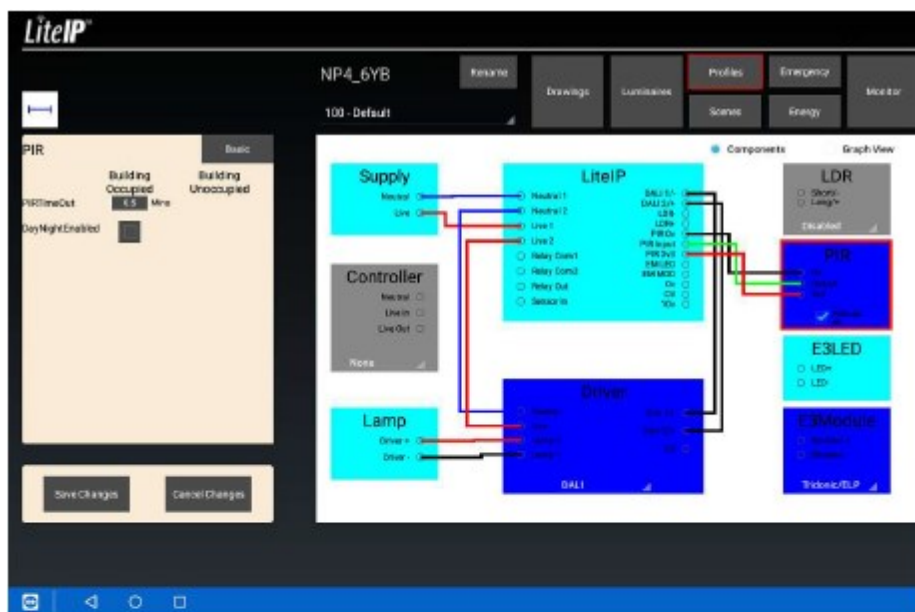

7) Installing the Luminaire



Applying Profiles

Once you've set up your profiles make sure you're on the Configure tab in the settings panel and then drag a box over the luminaires that you wish to apply it too. To create the box start top left of the area where you wish the box to start and drag diagonally down to the bottom right of where you want the box to end as shown by the arrow in the screenshot opposite (you can also individually tap on a luminaire to do the same if you wish, but this is demonstrating how to change an entire group)

Once selected tap on the drop-down menu in the settings panel and you will see all your created Profiles, select the one you want and it will automatically apply it to all selected devices. You will see the number above the luminaire change to your new profile, this indicates your change has been applied.

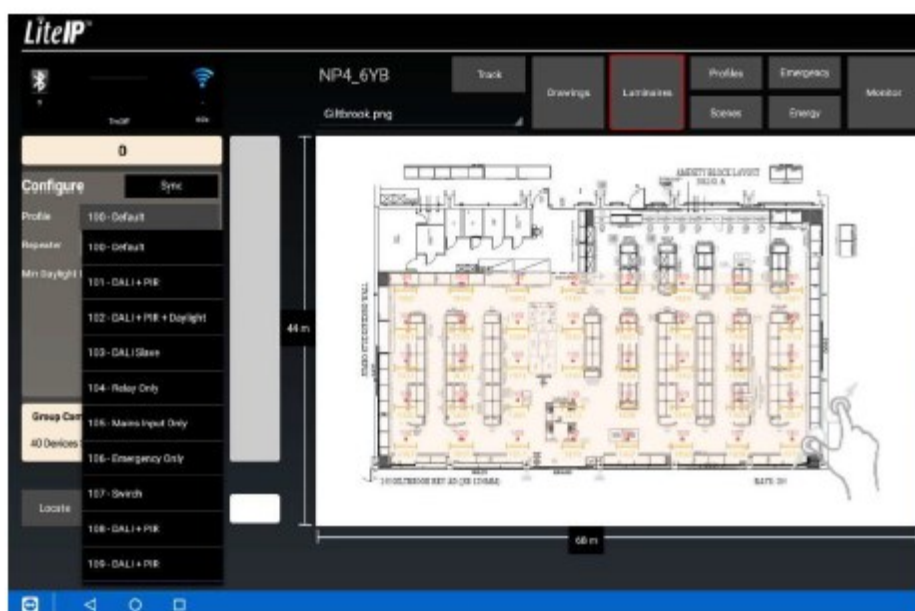
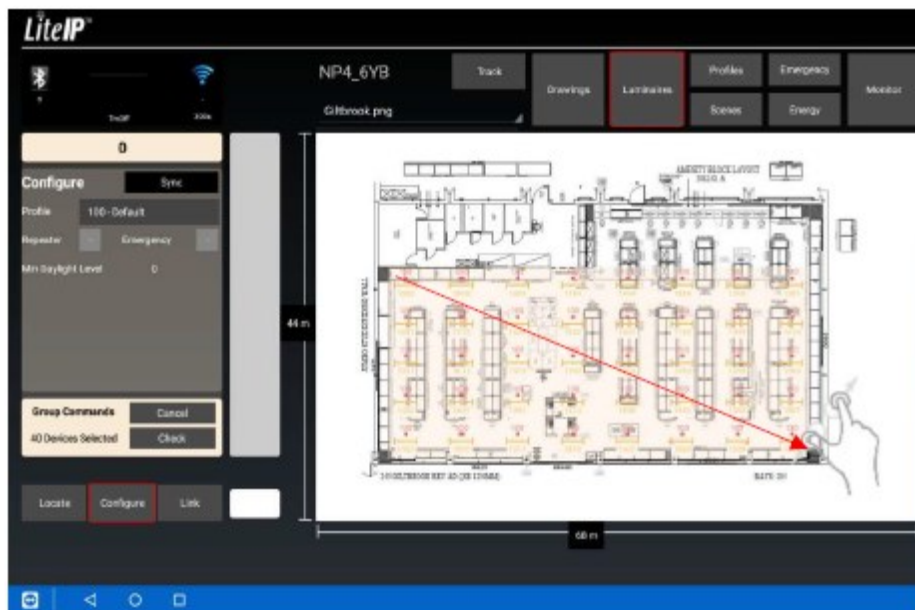

7) Installing the Luminaire



Applying Profiles

Linking & Grouping Devices

To create control groups you want to be on the Link tab in the settings panel and select the group of luminaires you wish to apply your grouping methodology to. Once you've selected the group you will get a few options appear on the left which are:

- x Cancel – Cancel your current selection
- x Link All (X) – Link all currently selected devices to each other
- x Unlink All – Unlink all currently selected devices
- x Link from X – Create a link from a certain device to all currently selected devices
- x Link to X – Create links from all currently selected devices to a certain device
- x Me & 2 – Hold on this to change 2 to any value, this will then link each device to its

X nearest devices across the selected group (see second screenshot for example)

- x Link to Self – Link luminaires to themselves so they will operate independently
- x Daylight – Link luminaires to a daylight sensor
- x Check – Refresh the status of luminaires

Links can be deleted at any time by tapping on the link and selecting Delete.

You can create single direction links manually by dragging your finger from the device you wish to link to the one you wish to link it to. If you tap on a luminaire whilst in the Link tab you will see all current links to that device.

To see daylight links you must select the daylight option within the settings tab once you have selected a device. These links will be shown in yellow.

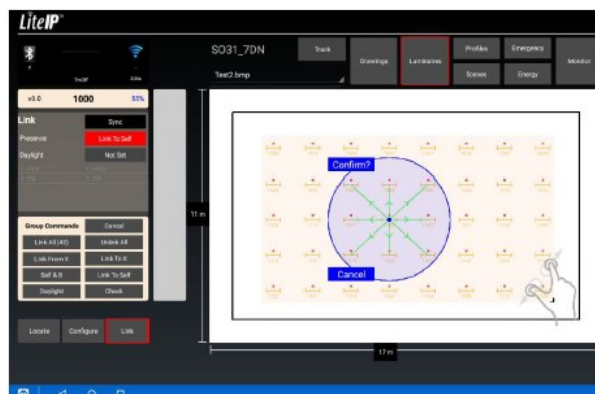
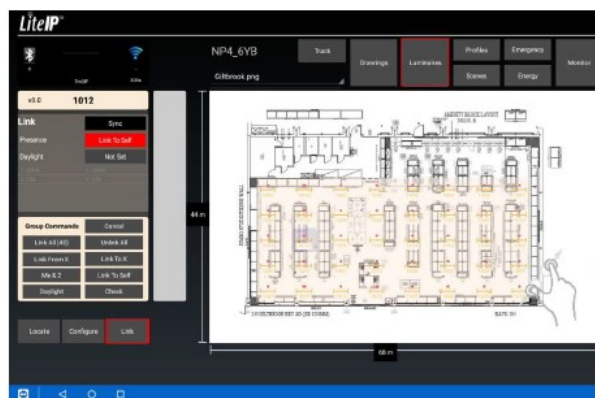

7) Installing the Luminaire



Finding & Adding Luminaires

To find and add live devices to a site once you are ready you will need to make sure the Bluetooth interface is connected and then press the Find button, this will then begin to search for the nearest 2-10 devices within range. Once it has completed its search it will populate the Search Bar with the devices it has found. Each of these will have a percentage value next to it, this indicates the signal strength between the interface and device and thus the highest percentage nodes will be the closest to you.

Tapping on one of the devices will give you an "ON" and "OFF" option, this allows you to override the luminaire into an OFF or ON state for 5 seconds so you can identify which luminaire it is.

You can then simply hold your finger down on the device for 1 second and then drag it to the location you require in the Drawing Panel.

If you are replacing a simulated luminaire with a real device you simply need to drag the device over the top over the simulated device and you will be asked do you want to replace XXXX with XXXXX, simply press yes and it will take on all the settings of the simulated device and replace it.

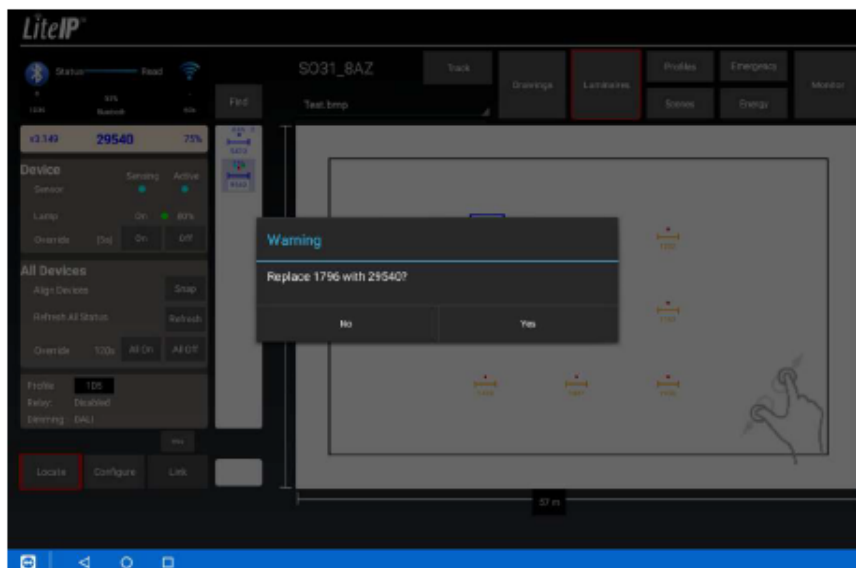
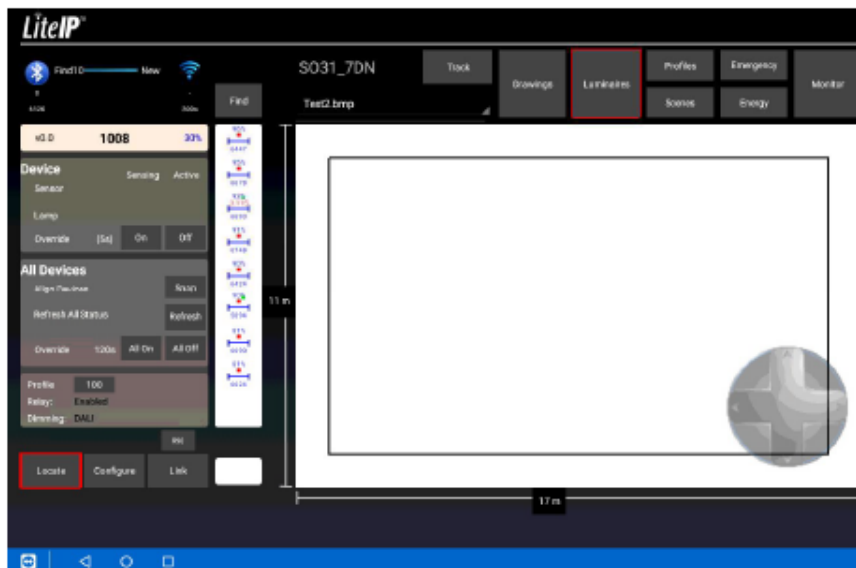

7) Installing the Luminaire



CONFIGURING SOFTWARE

1.- PROFILES.

- To create profiles, please select the following components:
- LiteIP NODE. Select Microwave option in the menú.
 - Controller. Select Microwave option too.
 - Driver: Enable DALI control.

If your luminaire integrates a RF sensor, please select and enable PIR. Make sure that RelayEnabled is NOT ticked.

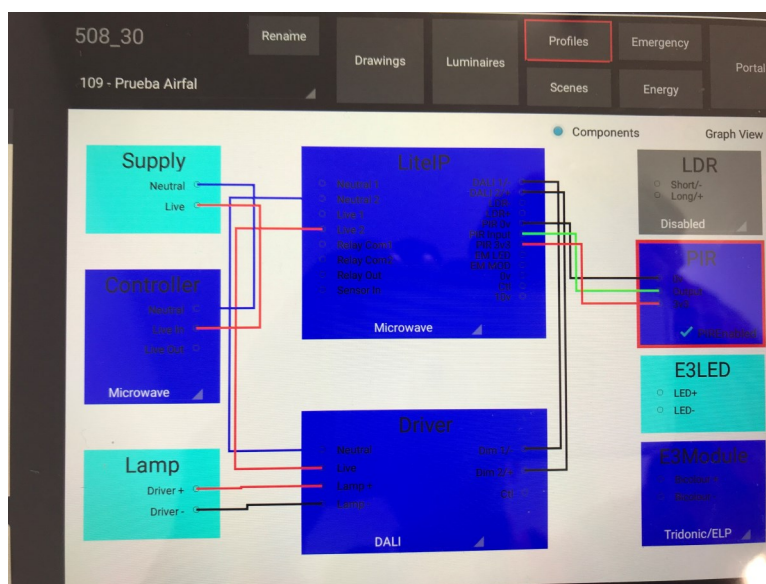

2.- Emergency versions.

If your luminaire integrates Emergency system, please check the EM option in following screen:

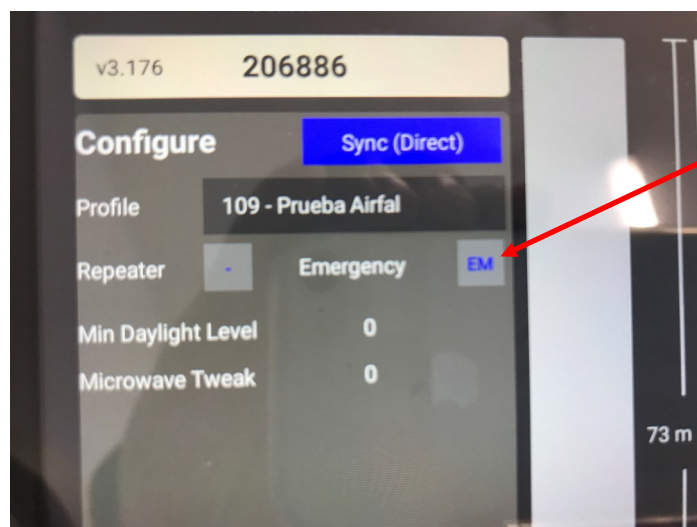

7) Installing the Luminaire



7.2.- Installig Optional Collator data.

If you choose to install the optional collator (440mm enclosure), simply connect to the power source. It Will detect all Wire-less node in a 100m range, and send data to the cloud., to the pre-configured Account in each node. Be sure that 3G dongle is plugged and activity led is active.



Wiring schematic:
Connect power cables to terminal block. 220-240V AC.

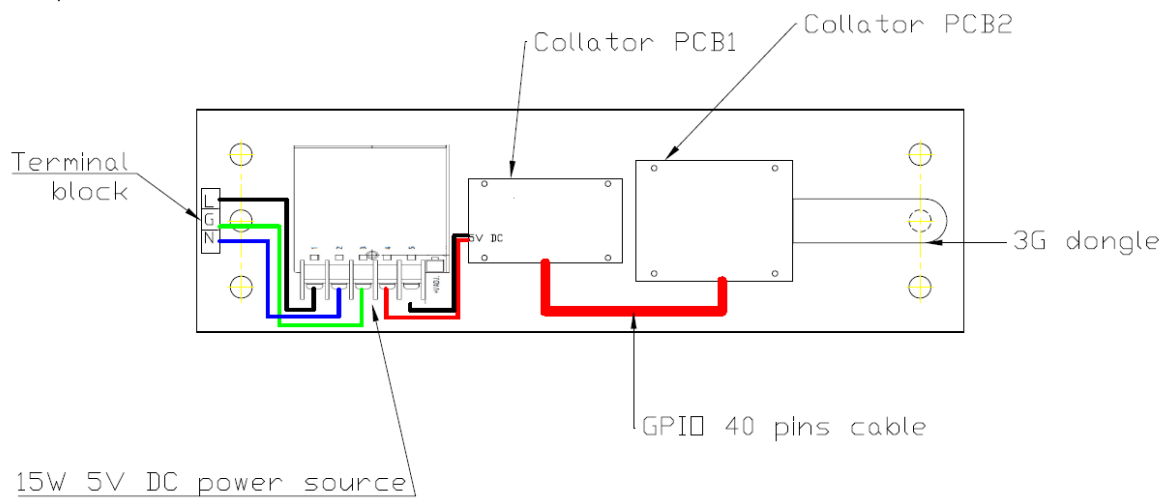

7) Installing the Luminaire



7.3.- INSTALLING PYROS WITH ATENEA WIRELESS SYSTEM.

If you choose to install the optional **ATENEA WIRELESS CONTROL MODULE SYSTEM**, you don't need to make anything special. Each luminaire equipped with Atenea Will be identified with a unique number. This number Will be placed in a installation drawing, showing the exact place of installation. After connecting the luminaire to the power line, Atenea module Will search for a Atenea Gateway. Once establish comminication, it Will receive the profile of functioning fromthe cloud, and it Will Works in the way that have beed pre-programmed at factory. User can't modify this profile neither modify LED current or power.



Simply ensure that optional motion sensor is orientated towards persons way, to detect movements. Ensure there are not metallic external parts covering antenna.

DO NOT COVER ANTENNA WITH METALLIC PIECES

Changing functioning profile or turning on/off the luminaire Will be only available to users with special access privileges from the WEB application, or from Airfal Factory under request. Quick acces to 100% power, ON/OFF or other special functions Will be agreed between final user and Airfal before installing luminaires.

INSTALLING ATENEA GATEWAY.

There is a special Pyros in 440mm versión enclosure with an Atenea Gateway installed. There is a 4G antenna, a power source and the Atenea Gateway totally Functional, supplied from factory. Installer only needs to power the Gateway on the terminal block. The Gateway Will start autmatically, connect with the CLOUD, and search for luminaires in range. Normally, one Gateway is necessary each 200 luminaires, and it must be placed in the middle of all the luminaires controlled. Airfal Will determine over installation drawing optimal position. See ATENEA datasheets for more information.

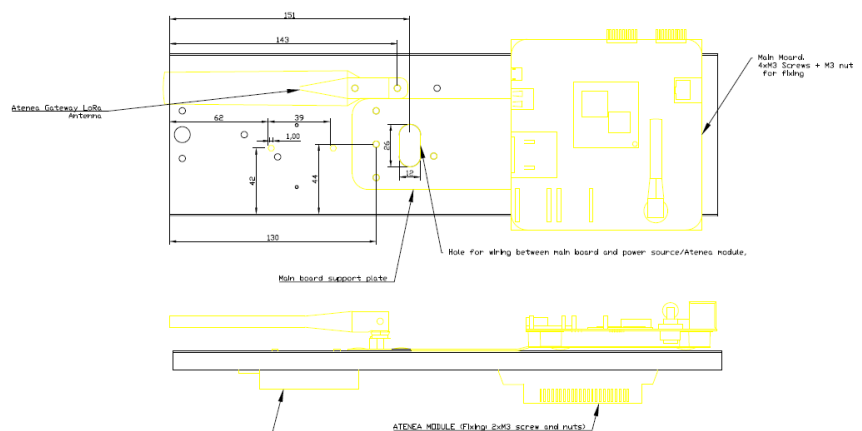
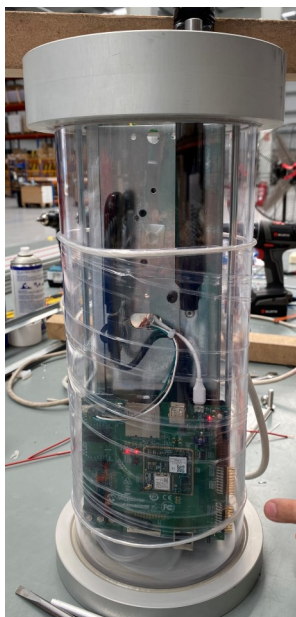

8.1 Cleaning the luminaire

Clean the luminaire with a damp cloth only, after first ensuring that there is no explosive atmosphere present. For use in environments where combustible dusts may be present, the user must carry on regular cleaning of the apparatus so as to prevent build-up of dust to surface (thickness < 5mm).



8.2 Replacing fluorescent tube

Before opening the light fitting, ensure that there is no explosive atmosphere present.

After switching off light fitting, wait for 30 MINUTES before opening the light fitting.

1. Use a 6 mm Allen key to remove the three screws that hold the closing cap, as seen in the figure. Then remove the closing cap, keeping it perpendicular with respect to the light fitting axis in order to facilitate its removal and disconnect the female plug by hand (**do not pull the power supply cable !!**).
2. Remove the stop pins from the reflector guide and remove the reflector from the light fitting.
3. Replace the fluorescent tubes by inserting them in the lamp holders and turning them through 90°.



The fluorescent tubes must be replaced with others of the same specifications and power rating.

3. Replace the reflector in its original position in the light fitting (ensure that the guide pin is on the same side as the fluorescent tubes).

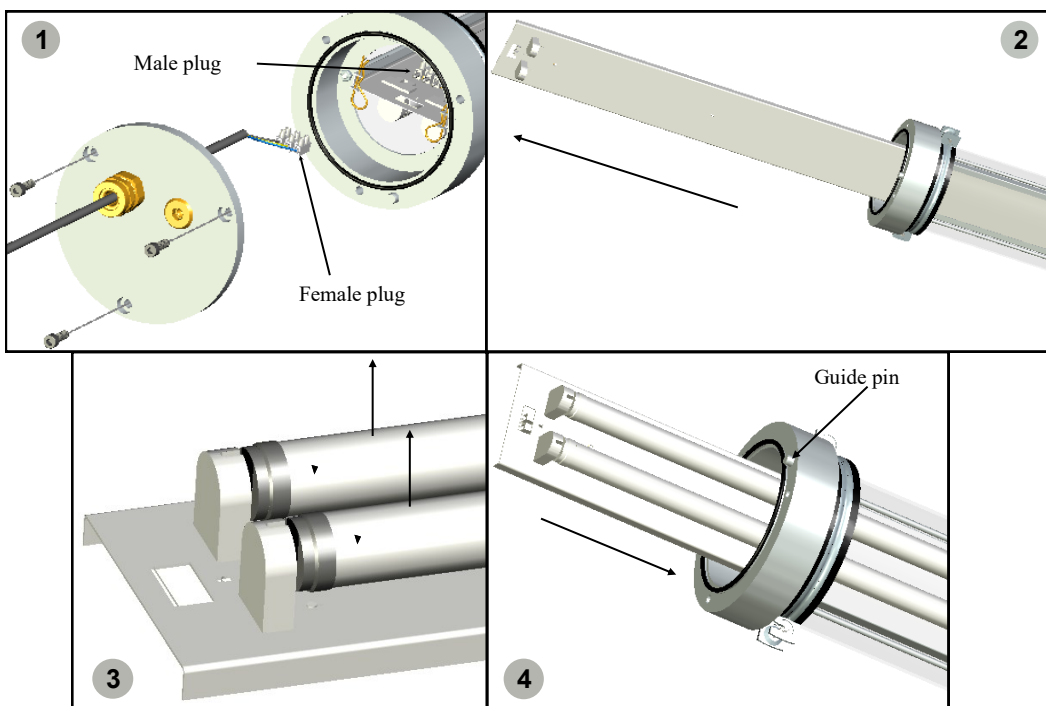

8) Maintenance



5. Replace the two stop pins in the reflector guides.
6. Reconnect the terminal block.
7. Close the light fitting, ensuring that the upper cap guide pin fits into the hole on the closing cap.
8. Use a 6 mm Allen key to tighten the three screws which hold the closing cap.
9. Turn on the power and make sure the light fitting tubes are working correctly.
10. REPLACEMENT OF THE BATTERY PACK, please contact the manufacturer.

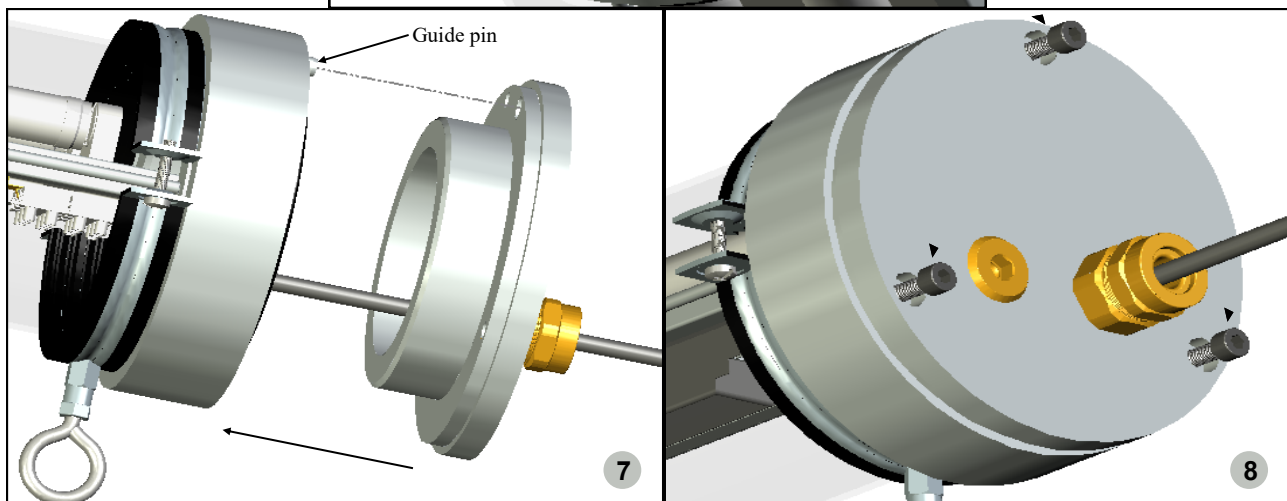
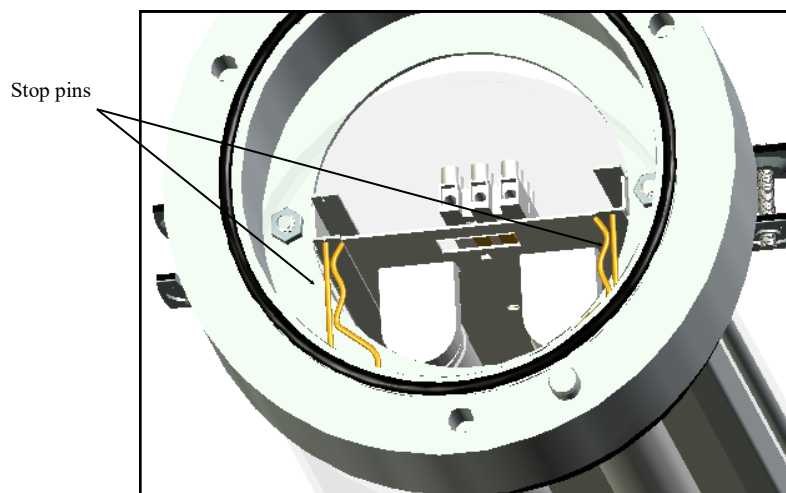

Check that all components are correctly fitted in their respective positions and that all fastenings have been fully tightened.

AIRFAL INTERNATIONAL S.L. will not be held responsible for any problem resulting from incorrect or incomplete assembly and connection.

8.3 Replacing LED tube.

Before opening the light fitting, ensure that there is no explosive atmosphere present. After switching off light fitting, wait for 30 MINUTES before opening the light fitting.



1. Use a 6 mm Allen key to remove the three screws that hold the closing cap, as seen in the figure. Then remove the closing cap, keeping it perpendicular with respect to the light fitting axis in order to facilitate its removal and disconnect the female plug by hand (**do not pull the power supply cable !!**).

2. Remove the stop pins from the reflector guide and remove the reflector from the light fitting.
3. Replace the LED tubes by inserting them in the lamp holders and turning them through 90°.

The LED tubes must be replaced with others of the same specifications, same connctions and power rating.

4. Replace the reflector in its original position in the light fitting (ensure that the guide pin is on the same side as the LED tubes).
5. "REPLACEMENT OF THE BATTERY PACK, please contact the manufacturer."



6. LED MODULE REPLACING: Contact with Factory. LED modules not REPLACEABLE.

7.- Collator Maintenance: Collator parts are not replaceable. In case of failure, please contact manufacturer.

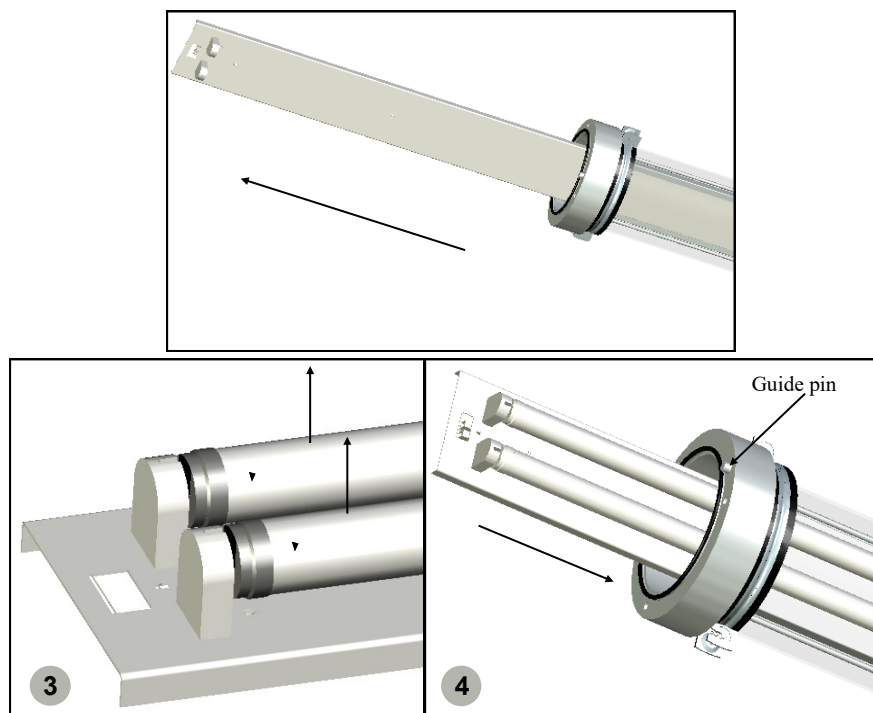

8.4 Optional double-closing cap and through-wiring.

In case you choose the optional double closing cap, the procedure to open and extract the gear tray is the same, but in the two ends of the luminaire. Simply move the internal gear tray first to one end and then to the other to connect to the double symmetric terminal block, in order to connect the two sides of the luminaire. After all, move the gear tray to its final position centered in the luminaire, put the pins in their places and close both caps.



1. Use a 6 mm Allen key to remove the three screws that hold each closing cap, as seen in the figure. Then remove the closing cap, keeping it perpendicular with respect to the light fitting axis in order to facilitate its removal and disconnect the female plug by hand (**do not pull the power supply cable !!**).

2. Remove the stop pins from the reflector guide and remove the reflector from the light fitting.
3. Replace the LED tubes by inserting them in the lamp holders and turning them through 90°.

The LED tubes must be replaced with others of the same specifications, same connections and power rating.

4. Replace the reflector in its original position in the light fitting (ensure that the guide pin is on the same side as the LED tubes).



5. "REPLACEMENT OF THE BATTERY PACK, please contact the manufacturer."

6. LED MODULE REPLACING: Contact with Factory. LED modules not REPLACEABLE.

1

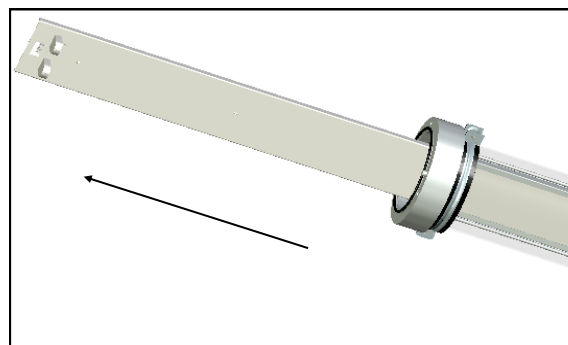

2

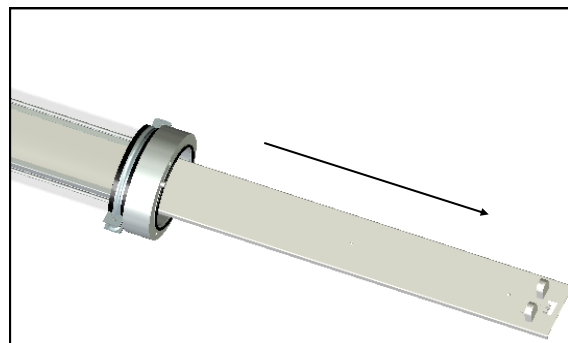

9) Parts list

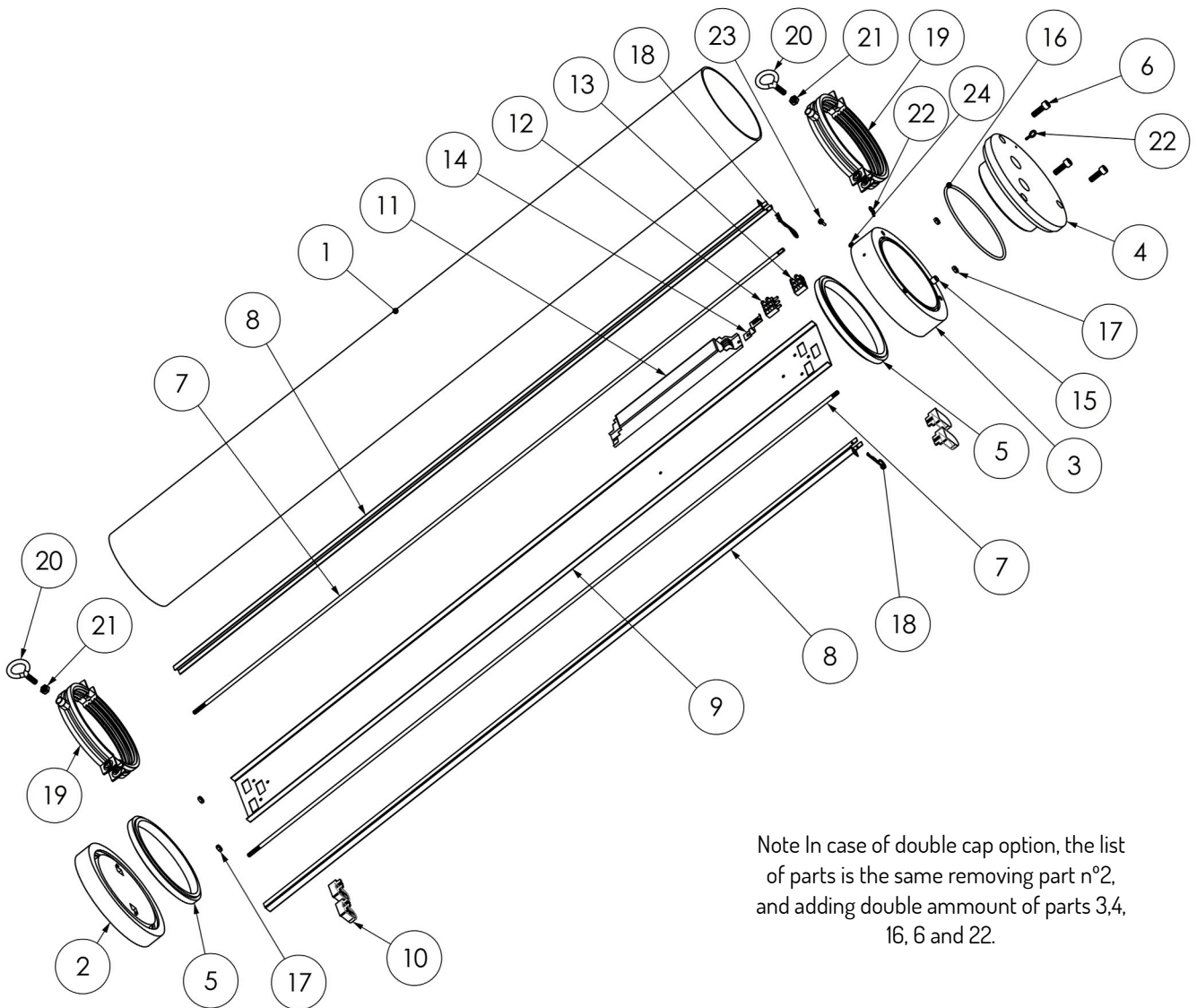

Note In case of double cap option, the list of parts is the same removing part n°2, and adding double amount of parts 3,4, 16, 6 and 22.

Item	Units	Description	Item	Units	Description
1	1	Polycarbonate tube	14	1	Support tab
2	1	Lower cap	15	1	Guide pin
3	1	Upper cap	16	1	O-ring seal
4	1	Closing cap	17	4	M6 nuts
5	-	Polyurethane resin	18	2	Stop pin
6	3	M8 Allen screws	19	2	Clamp
7	2	Fixing bar	20	2	Fixing eye bolts
8	2	Reflector guide	21	2	M8 eye bolt nut
9	1	Reflector	22	2	Chain eye bolt
10	4	Lamp holder (flor-Led tube only)	23	1	External Earth screw
11	1	Ballast / LED driver	24	1	Earth washer
12/13	1	Terminal block			

9) Parts list



9.1 Parts list (LED VERSIONS).

In LED module versions, the enclosure is exactly the same, but the internal parts on the gear tray are different. The LED modules parts are:

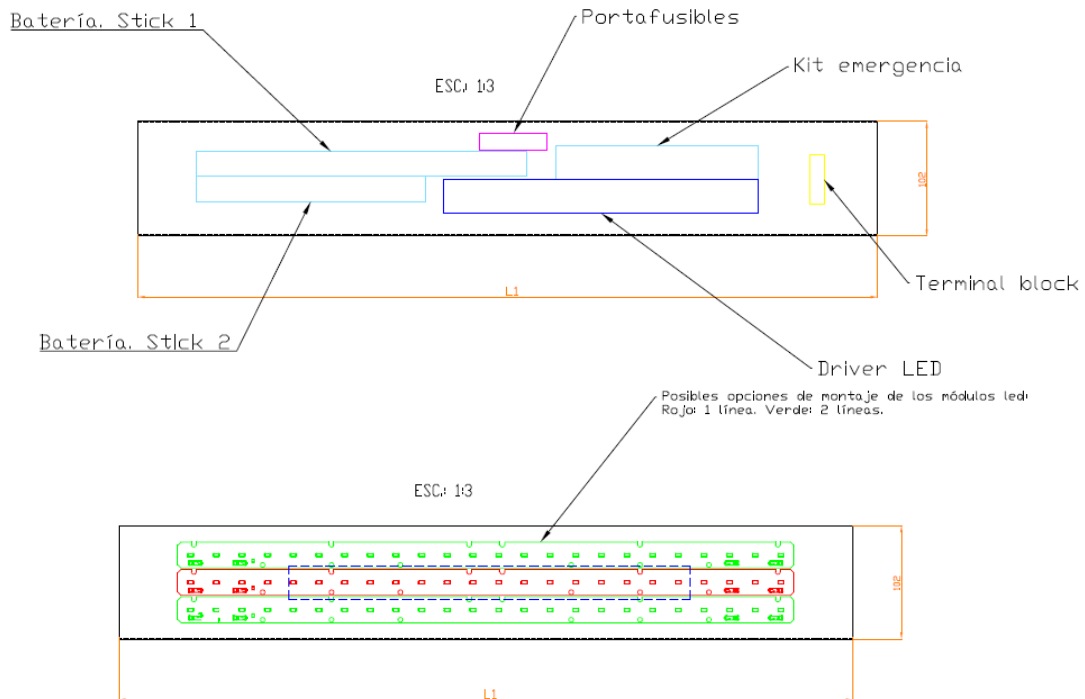

In case of Wireless control version, the special parts layout is this:

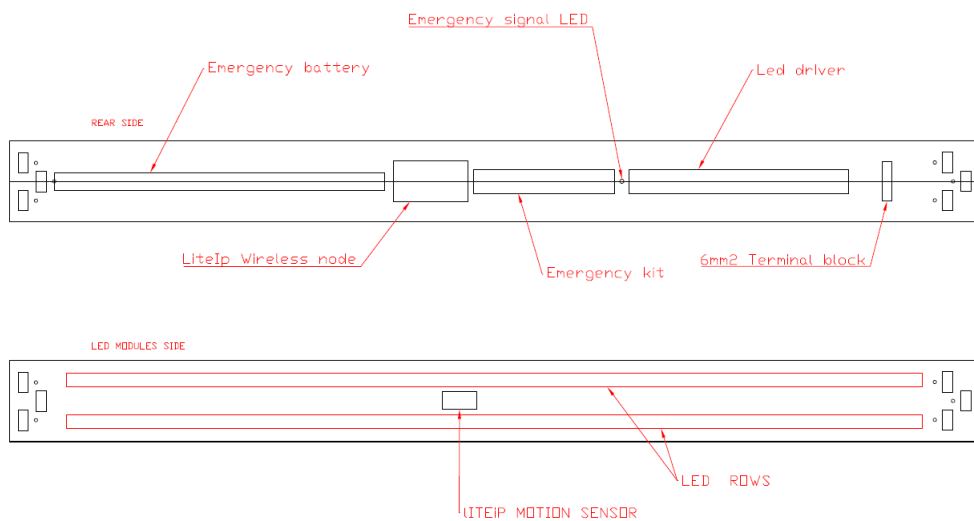

9) Parts list



In case of Double Closing Cap version, the layout of terminal blocks and through wiring is this:

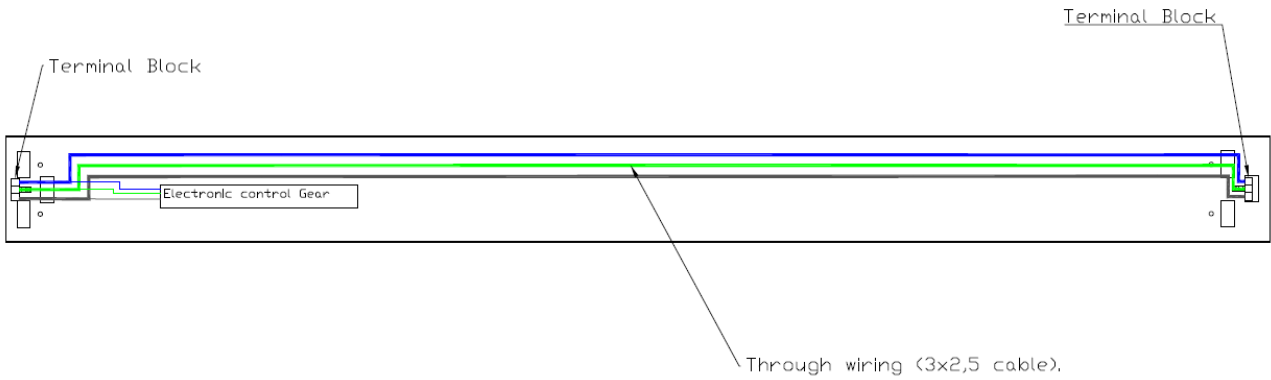

Use terminal blocks in both sides to connect to power line.

Collator Layout:

While introducing collator's gear tray,, please be careful with 40 pins cable. Avoid to damage it.

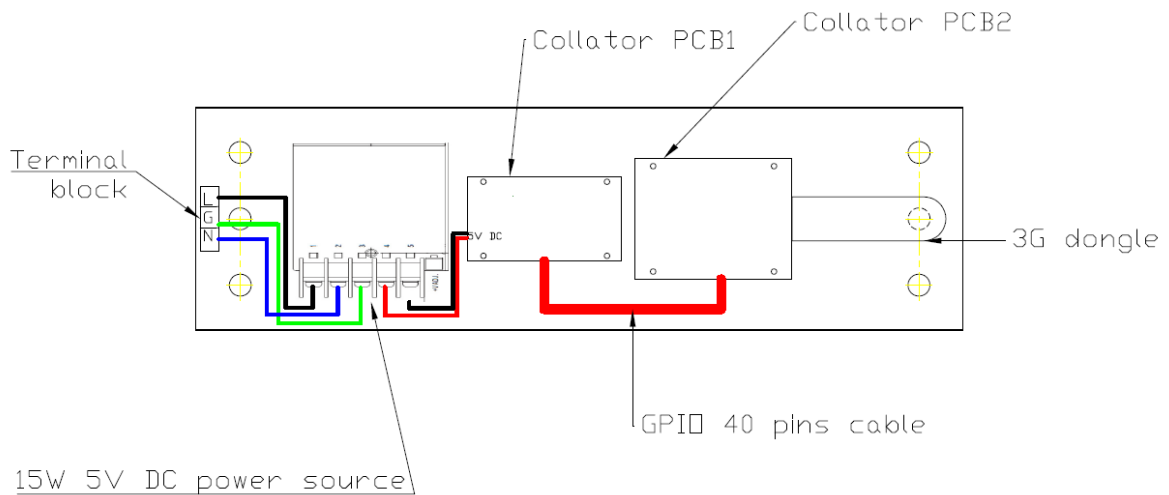

10) Warranty conditions



10.1 Warranty conditions

AIRFAL INTERNATIONAL S.L. guarantees that the **Pyros** luminaire will work correctly for a period of 24 months from the date of purchase. LED module version have 5 years warranty (see General Warranty Conditions).

10.2 Cover

The repair of all manufacturing defects or the substitution of defective parts will be free at our installations, including parts and labour.

This guarantee does NOT cover damage or imperfection caused by the improper use of the equipment (see details in the following section).

10.3 Exceptions

The guarantee and other rights recognized here will be void in the event of damage and/or deterioration produced as a result of:

- a) Force Majeure (Atmospheric or geological phenomena, fire, etc.)
- b) Incorrect or non-regulatory installation and/or connection. Incorrect connection/cabling for electrical and electronic elements.
- c) Intervention by unauthorized personnel.
- d) Handling and/or modification of luminaire elements without prior authorization.
- e) Manipulation of data on the rating plates of the light fitting, or in this document.
- f) Incorrect transportation or storage conditions.
- g) Service conditions which are inappropriate for the specifications and technical performance of the lamp:
 - Unstable power supply.
 - Inappropriate atmospheric conditions: ambient temperature range, humidity, condensation, aggressive atmospheres, etc.
- h) Incorrect assembly and installation conditions for the light fitting and its operation.
- i) Batteries are guaranteed for two years from the date of delivery.

All conditions NOT represented in this document must be previously accepted in writing by AIRFAL INTERNATIONAL S.L. Likewise AIRFAL INTERNATIONAL S.L. reserves the right to modify this document without prior notification.

11.1).- SPECIFIC CONDITIONS OF USE:

- The equipment is intended to be used in an ambient temperature range of:

From -20°C up to +50°C when mounting T8 lamps of 36W or 58W with the optional emergency kit.

From -20°C up to +55°C for standard fluorescent versions and LED tubes.

From -20°C up to +50°C for LED MODULES versions, I-Pyros and Collator.

- Flameproof joint are not intended to be repaired.
- The screws used for the closing cap of explosion-proof enclosure must be in stainless steel with quality higher or equal to A2-70. Screws are supplied.

- During the installation, the user will take into consideration that the equipment underwent only a shock corresponding to an energy of a low risk.

- For the risk from electrostatic discharge, the user shall read this instructions, section 8.1.

11.2.- Technical Support.

Each luminaire is accompanied by technical documentation on supply by AIRFAL INTERNATIONAL S.L. In the event of any part of this documentation being missing, contact the supplier or distributor of the equipment.

For any information request or enquiry regarding a supplied luminaire, the **Serial Number** of the said equipment must be given, which can be found on its rating plate.

Address of the manufacturer and technical support is:

AIRFAL INTERNATIONAL, S.L.
C/ Rio Esera Nº 5
E-50830 VILLANUEVA DE GALLEGO
ZARAGOZA - ESPAÑA
Tel.: +34 976 185 809
Fax: +34 976 186 086
e-mail: tecnico@airfal.com
web: www.airfal.com

12) Technical specifications



Power supply:	230V. 50Hz
Degree of protection:	IP-66
Certificate of EC Type:	INERIS 14ATEX0064X under directive 2014/34/EU
Mode of protection:	(All versions).



II 2 GD Ex db IIB + H2 T6 Gb
Ex tb IIIC T85 °C Db

Cable: Not included

Range:

Fluorescent version:

18W model Fluorescent T8, 18W

Luminaire length: 748 mm.
Approx. weight: 9.68 Kg.
General diameter: 190 mm.

36W model

Fluorescent T8, 36W
Luminaire length: 1357 mm.
Approx. weight: 11.38 Kg.
General diameter: 190 mm.

58W model

Fluorescent T8, 58W
Luminaire length: 1659 mm.
Approx. weight: 12.23 Kg.
General diameter: 190 mm.

LED TUBES model

LED Tube (1 or 2 tubes)
600 mm, 1200 mm, 1500 mm

12) Technical specifications



LED modules version:

7/14W models

LED modules up to 14W.
Luminaire length: 440 mm.
Approx. weight: 4,7 Kg.
General diameter: 190 mm .

Fluorescent control equipment: Electronic ballast with preheat starter

LED modules control equipment: Electronic driver.

Assembly accessories: 2 zinc-plated steel clamps with rubber protection and two steel eye bolts

Ambient work temperature:

From -20°C up to +50°C when mounting T8 lamps of 36W or 58W with the optional emergency kit.

From -20°C up to +55°C for standard fluorescent versions and LED tubes.

From -20°C up to +50°C for LED MODULES versions, I-Pyros and Collator.

Materials

- End caps in aluminium. Tube of 4 mm thickness impact-resistant polycarbonate.
- Steel screws. Rubber O-ring seal. Zinc-plated steel clamps.
- Steel fixing bars. Steel reflector guides.
- Painted steel reflector
- Each fixing screw for the closing cap in nickel-steel.